

Your Global Automation Partner

TURCK

REI...

Encoders with Incremental Interface

Instructions for Use

Contents

- 1 About these instructions 3
 - 1.1 Target groups 3
 - 1.2 Explanation of symbols used..... 3
 - 1.3 Other documents 3
 - 1.4 Feedback about these instructions 3
- 2 Information about the product 4
 - 2.1 Product identification 4
 - 2.2 Scope of delivery..... 4
 - 2.3 Turck service 4
- 3 For your safety 5
 - 3.1 Intended use 5
 - 3.2 Obvious misuse 5
 - 3.3 General safety notes..... 5
- 4 Product description 6
 - 4.1 Device overview 6
 - 4.2 Operating principle 6
 - 4.3 Functions and operating modes 7
 - 4.3.1 Output function 7
 - 4.4 Technical accessories 7
- 5 Installing 8
 - 5.1 Mounting the solid shaft encoder using a coupling 9
 - 5.2 Mounting the hollow shaft encoder using a coupling 10
- 6 Connection 11
 - 6.1 Wiring diagram..... 11
- 7 Commissioning 12
- 8 Troubleshooting..... 13
- 9 Maintenance 14
- 10 Repair 14
 - 10.1 Returning devices 14
- 11 Disposal..... 14
- 12 Turck subsidiaries — contact information 15

1 About these instructions

These instructions for use describe the structure, functions and the use of the product and will help you to operate the product as intended. Read these instructions carefully before using the product. This is to avoid possible damage to persons, property or the device. Retain the instructions for future use during the service life of the product. If the product is passed on, pass on these instructions as well.

1.1 Target groups

These instructions are aimed at qualified personal and must be carefully read by anyone mounting, commissioning, operating, maintaining, dismantling or disposing of the device.

1.2 Explanation of symbols used

The following symbols are used in these instructions:



DANGER

DANGER indicates a dangerous situation with high risk of death or severe injury if not avoided.



WARNING

WARNING indicates a dangerous situation with medium risk of death or severe injury if not avoided.



CAUTION

CAUTION indicates a dangerous situation of medium risk which may result in minor or moderate injury if not avoided.



NOTICE

NOTICE indicates a situation which may lead to property damage if not avoided.



NOTE

NOTE indicates tips, recommendations and useful information on specific actions and facts. The notes simplify your work and help you to avoid additional work.



CALL TO ACTION

This symbol denotes actions that the user must carry out.



RESULTS OF ACTION

This symbol denotes relevant results of actions.

1.3 Other documents

Besides this document, the following material can be found on the Internet at www.turck.com:

- Data sheet
- Quick Start Guide

1.4 Feedback about these instructions

We make every effort to ensure that these instructions are as informative and as clear as possible. If you have any suggestions for improving the design or if some information is missing in the document, please send your suggestions to techdoc@turck.com.

2 Information about the product

2.1 Product identification

These instructions apply to the following encoders with incremental output:

- REI...

2.2 Scope of delivery

The scope of delivery includes:

- Encoder – sensor
- Quick Start Guide

2.3 Turck service

Turck supports you with your projects, from initial analysis to the commissioning of your application. The Turck product database under www.turck.com contains software tools for programming, configuration or commissioning, data sheets and CAD files in numerous export formats.

The contact details of Turck subsidiaries worldwide can be found on p. [▶ 15].

3 For your safety

The product is designed according to state-of-the-art technology. However, residual risks still exist. Observe the following warnings and safety notices to prevent damage to persons and property. Turck accepts no liability for damage caused by failure to observe these warning and safety notices.

3.1 Intended use

The encoders with incremental output are used to measure angular movements. To do this, the devices record mechanical rotary movements and convert them into electrical pulse sequences. A defined number of pulses is output per revolution.

The devices may only be used as described in these instructions. Any other use is not in accordance with the intended use. Turck accepts no liability for any resulting damage.

3.2 Obvious misuse

- The devices are not safety components and must not be used for personal or property protection.
- Any use that exceeds the maximum permissible mechanical speed (see technical data) is deemed to be not in accordance with the intended purpose.

3.3 General safety notes

- The device meets the EMC requirements for industrial areas. When used in residential areas, take measures to avoid radio interference.
- The device may only be assembled, installed, operated, parameterized and maintained by professionally-trained personnel.
- The device may only be used in accordance with applicable national and international regulations, standards and laws.
- If safe operation is no longer guaranteed: Take the device out of operation and ensure that it cannot be switched on again accidentally.

4 Product description

The encoders of the REI... product series are available as versions with a solid shaft or hollow shaft. The devices are available in three sizes ranging from 36 to 100 mm, in all common resolutions.

The incremental encoders emit electrical pulses that can be used to determine position and calculate speed.

4.1 Device overview

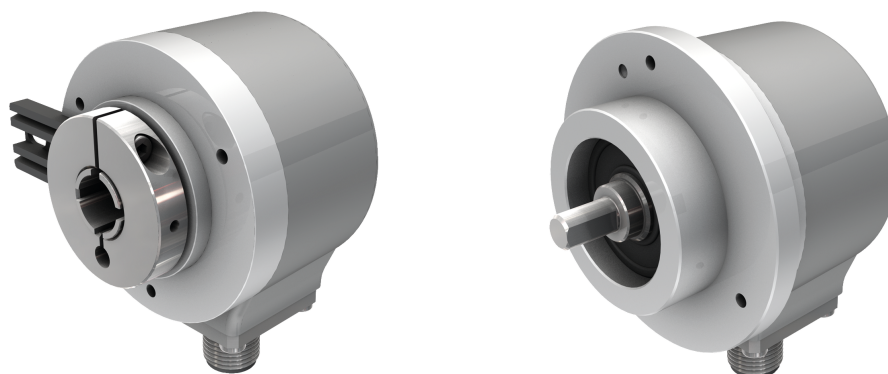

Fig. 1: Example — encoder with hollow shaft Fig. 2: Example — encoder with solid shaft

4.2 Operating principle

Encoders detect rotational movements, such as the angle velocity of a shaft. Encoders convert the rotational movements into electrical signals. The devices pass on the electrical signals to a higher-level controller for evaluation. Encoders are designed as absolute and incremental encoders with hollow or solid shafts.

Absolute encoders also supply the angle value after a startup if the value has changed when deactivated. Incremental encoders only detect position changes when active by counting periodic patterns. This normally involves the optical scanning of a rotating disk.

4.3 Functions and operating modes

4.3.1 Output function

The output signal of the incremental encoder is based on the HTL (high transistor logic) interface or the TTL (transistor-transistor logic) interface. Depending on the model, the inverted signals A (inverse) and B (inverse) are output in addition to tracks A and B. A Z-track is also available, for which an inverted value is also output depending on the model.

The half-period of the signal is inversely proportional to the rotational speed. The angle for positioning is captured accurately using the number of output pulses.

The number of output pulses varies depending on the device type.

For evaluation of the output signal, Turck recommends using standard input cards or counter blocks that can process a minimum pulse frequency of 80 kHz.

4.4 Technical accessories

Dimension drawing	Type	ID	Description
	RKC8T-2/TXL	6625142	Connection cable; M12 female connector, straight, 8-pin, cable length 2 m, jacket material: PUR, black; suitable for trailing, weld splatter resistant, chemical, UV, and oil-resistant, flame-retardant, halogen, silicone, PVC, and LABS-free, particularly abrasion-resistant; cULus approved; RoHS compliant; degree of protection IP67; other cable lengths and types available, see www.turck.com

5 Installing



NOTICE

Incorrect mounting

Risk of damage to the sensor

- ▶ Do not modify or disassemble the encoder.
- ▶ Do not make adjustments to the shaft after mounting.
- ▶ Do not use a hammer to align the device.
- ▶ Avoid impact loads.
- ▶ Load the encoder shaft only within the permissible values (see technical data).
- ▶ Do not rigidly connect the rotary encoder to shafts and flanges at the same time. Use the coupling between the drive shaft and the encoder shaft or the hollow shaft encoder flange.

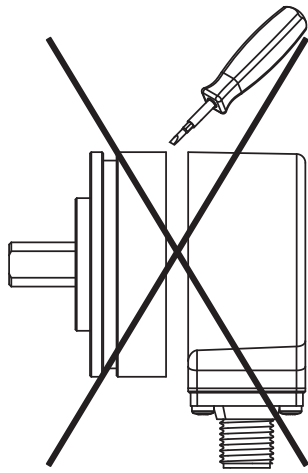

Fig. 3: Mounting view — do not open

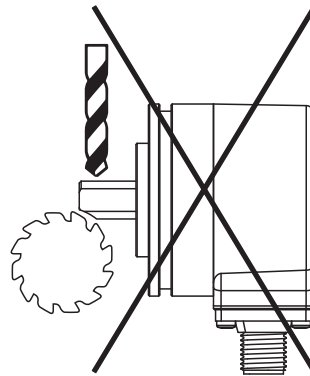

Fig. 4: Mounting view — do not make adjustments after mounting

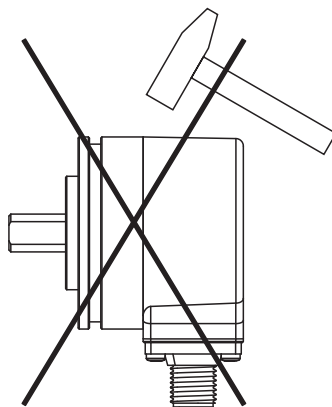

Fig. 5: Mounting view — do not use a hammer to align the device

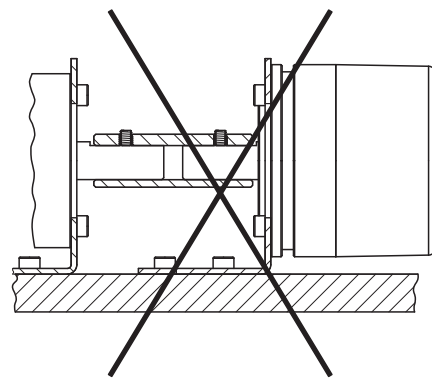

Fig. 6: Mounting view — do not rigidly connect the device to shafts and flanges at the same time

5.1 Mounting the solid shaft encoder using a coupling

- ▶ Check shaft for displacement.
- ▶ Refer to the technical data for the coupling for the maximum axial displacement, radial displacement, and angular displacement values.

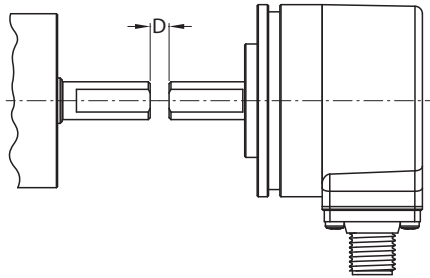

Fig. 7: Axial displacement

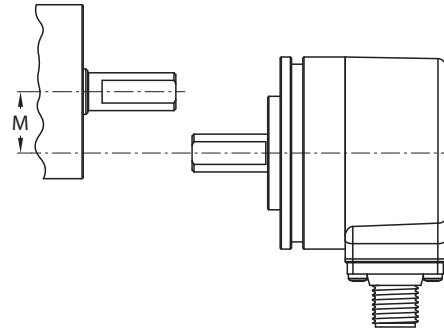

Fig. 8: Radial displacement

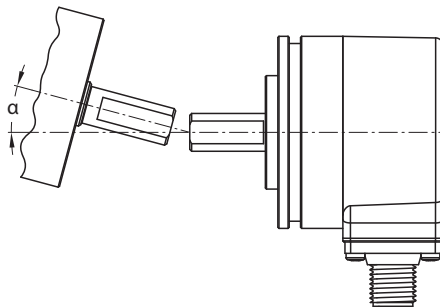

Fig. 9: Angular displacement

- ▶ During mounting, protect the coupling against excessive bending and damage.
- ▶ Align the coupling on the shaft.
- ▶ Secure the coupling on the device using tensioning screws or clamping screws. For the maximum tightening torque, refer to the data sheet of the screws used.

5.2 Mounting the hollow shaft encoder using a coupling

- ▶ Mount the encoder with the coupling on the shaft.

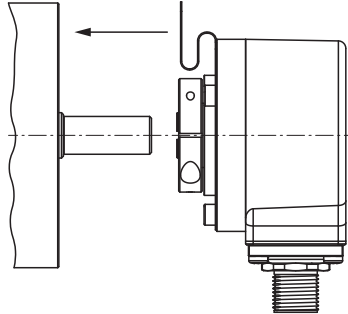

Fig. 10: Mounting on the shaft with the coupling

- ▶ Screw the coupling to the drive flange.

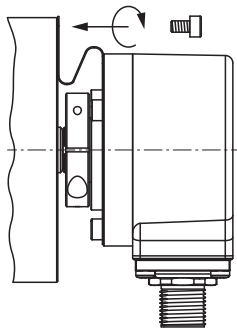

Fig. 11: Screwing the coupling to the drive flange

- ▶ Carefully tighten the clamping hub.

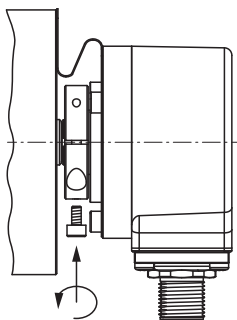

Fig. 12: Tightening the clamping hub

6 Connection

The encoder has a 5-pin or 8-pin M12 × 1 male connector with incremental output. The pin assignment can be found on the sensor label or the data sheet.

Turck recommends the following cable lengths:

- For asymmetrical transmission (no inverted signals): max. 10 m
 - For symmetrical transmission (e.g. RS422 standard): max. 50 m with twisted pairs
- ▶ Connect all required cable cores as per the wiring diagram. Insulate the cable ends that are not required to avoid short circuits.
 - ▶ Follow the operating instructions for the connecting cable used.
 - ▶ Disconnect the encoder from the connecting cable only when the encoder is de-energized.
 - ▶ Connect the shielding (if present) to the encoder housing.
 - ▶ The encoder and processor must always be switched on and off simultaneously.
 - ▶ Observe the operating voltage and maximum permissible output current (see technical data).

EMC-compliant installation

- ▶ Use shielded connection cables as control cables.
- ▶ For symmetrical transmission (e.g. via RS422): Use twisted pair cables.
- ▶ Connect protective earth to the rotary encoder and the evaluation unit (low impedance).
- ▶ Route the connection cables separately from cables with high noise levels.
- ▶ Do not connect devices with high noise levels to the encoder's power supply (e.g. frequency converters, solenoid valves, or contactors), or ensure that suitable voltage filtering is in place.

6.1 Wiring diagram

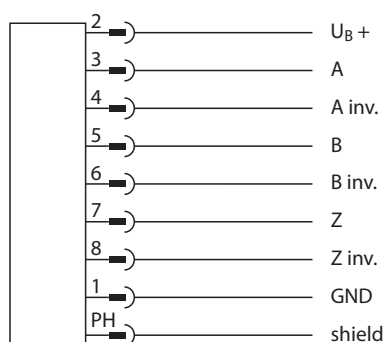

Fig. 13: Encoder REI... — wiring diagram

7 Commissioning

After connecting and switching on the power supply, the device is automatically ready for operation.

8 Troubleshooting

If the device does not function as expected, first check whether ambient interference is present. If there is no ambient interference present, check the connections of the device for faults.

If there are no faults, there is a device malfunction. In this case, decommission the device and replace it with a new device of the same type.

9 Maintenance

Ensure that the plug connections and cables are always in good condition.

The devices are maintenance-free, clean dry if required.

10 Repair

The device must not be repaired by the user. The device must be decommissioned if it is faulty. Observe our return acceptance conditions when returning the device to Turck.

10.1 Returning devices

Returns to Turck can only be accepted if the device has been equipped with a Decontamination declaration enclosed. The decontamination declaration can be downloaded from <https://www.turck.de/en/retoure-service-6079.php> and must be completely filled in, and affixed securely and weather-proof to the outside of the packaging.

11 Disposal



The devices must be disposed of correctly and must not be included in general household garbage.

12 Turck subsidiaries — contact information

Germany	Hans Turck GmbH & Co. KG Witzlebenstraße 7, 45472 Mülheim an der Ruhr www.turck.de
Australia	Turck Australia Pty Ltd Building 4, 19-25 Duerdin Street, Notting Hill, 3168 Victoria www.turck.com.au
Austria	Turck GmbH Graumanngasse 7/A5-1, A-1150 Wien www.turck.at
Belgium	TURCK MULTIPROX Lion d'Orweg 12, B-9300 Aalst www.multiprox.be
Brazil	Turck do Brasil Automação Ltda. Rua Anjo Custódio Nr. 42, Jardim Anália Franco, CEP 03358-040 São Paulo www.turck.com.br
Canada	Turck Canada Inc. 140 Duffield Drive, CDN-Markham, Ontario L6G 1B5 www.turck.ca
China	Turck (Tianjin) Sensor Co. Ltd. 18,4th Xinghuazhi Road, Xiqing Economic Development Area, 300381 Tianjin www.turck.com.cn
Czech Republic	TURCK s.r.o. Na Brne 2065, CZ-500 06 Hradec Králové www.turck.cz
France	TURCK BANNER S.A.S. 11 rue de Courtalin Bat C, Magny Le Hongre, F-77703 MARNE LA VALLEE Cedex 4 www.turckbanner.fr
Great Britain	TURCK BANNER LIMITED Blenheim House, Hurricane Way, GB-SS11 8YT Wickford, Essex www.turckbanner.co.uk
Hungary	TURCK Hungary kft. Árpád fejedelem útja 26-28., Óbuda Gate, 2. em., H-1023 Budapest www.turck.hu
India	TURCK India Automation Pvt. Ltd. 401-403 Aurum Avenue, Survey. No 109 /4, Near Cummins Complex, Baner-Balewadi Link Rd., 411045 Pune - Maharashtra www.turck.co.in
Italy	TURCK BANNER S.R.L. Via San Domenico 5, IT-20008 Bareggio (MI) www.turckbanner.it

Japan	TURCK Japan Corporation ISM Akihabara 1F, 1-24-2, Taito, Taito-ku, 110-0016 Tokyo www.turck.jp
Korea	Turck Korea Co, Ltd. B-509 Gwangmyeong Technopark, 60 Haan-ro, Gwangmyeong-si, 14322 Gyeonggi-Do www.turck.kr
Malaysia	Turck Banner Malaysia Sdn Bhd Unit A-23A-08, Tower A, Pinnacle Petaling Jaya, Jalan Utara C, 46200 Petaling Jaya Selangor www.turckbanner.my
Mexico	Turck Comercial, S. de RL de CV Blvd. Campestre No. 100, Parque Industrial SERVER, C.P. 25350 Arteaga, Coahuila www.turck.com.mx
Netherlands	Turck B. V. Ruiterlaan 7, NL-8019 BN Zwolle www.turck.nl
Poland	TURCK sp.z.o.o. Wroclawska 115, PL-45-836 Opole www.turck.pl
Romania	Turck Automation Romania SRL Str. Siriului nr. 6-8, Sector 1, RO-014354 Bucuresti www.turck.ro
Russian Federation	TURCK RUS OOO 2-nd Pryadilnaya Street, 1, 105037 Moscow www.turck.ru
Sweden	Turck Sweden Office Fabriksstråket 9, 433 76 Jonsered www.turck.se
Singapore	TURCK BANNER Singapore Pte. Ltd. 25 International Business Park, #04-75/77 (West Wing) German Centre, 609916 Singapore www.turckbanner.sg
South Africa	Turck Banner (Pty) Ltd Boeing Road East, Bedfordview, ZA-2007 Johannesburg www.turckbanner.co.za
Turkey	Turck Otomasyon Ticaret Limited Sirketi Inönü mah. Kayisdagi c., Yesil Konak Evleri No: 178, A Blok D:4, 34755 Kadiköy/ Istanbul www.turck.com.tr
USA	Turck Inc. 3000 Campus Drive, USA-MN 55441 Minneapolis www.turck.us

TURCK

Over 30 subsidiaries and
60 representations worldwide!

100008451 | 2023/01



www.turck.com