

Your Global Automation Partner

**TURCK**

REM...|RES...  
Encoders  
with Analog Output

Instructions for Use



# Contents

- 1 About these instructions ..... 5
  - 1.1 Target groups..... 5
  - 1.2 Explanation of symbols used ..... 5
  - 1.3 Other documents ..... 5
  - 1.4 Feedback about these instructions..... 5
- 2 Information about the product..... 6
  - 2.1 Product identification..... 6
  - 2.2 Scope of delivery ..... 6
  - 2.3 Turck service..... 6
- 3 For your safety ..... 7
  - 3.1 Intended use..... 7
  - 3.2 Obvious misuse..... 7
  - 3.3 General safety notes ..... 7
- 4 Product description..... 8
  - 4.1 Device overview ..... 8
  - 4.2 Operating principle..... 8
  - 4.3 Functions and operating modes ..... 9
    - 4.3.1 Output function..... 9
  - 4.4 Technical accessories..... 9
- 5 Installing..... 10
  - 5.1 Mounting the solid shaft encoder using a coupling..... 11
  - 5.2 Mounting the hollow shaft encoder using a coupling ..... 12
- 6 Connection..... 13
  - 6.1 Wiring diagram – current output ..... 13
  - 6.2 Wiring diagram – voltage output ..... 13
- 7 Commissioning ..... 14
- 8 Operation ..... 15
  - 8.1 LED display ..... 15
- 9 Troubleshooting ..... 16
- 10 Maintenance..... 17
- 11 Repair ..... 17
  - 11.1 Returning devices..... 17
- 12 Disposal ..... 17
- 13 Turck subsidiaries – contact information..... 18



# 1 About these instructions

These instructions for use describe the structure, functions and the use of the product and will help you to operate the product as intended. Read these instructions carefully before using the product. This is to avoid possible damage to persons, property or the device. Retain the instructions for future use during the service life of the product. If the product is passed on, pass on these instructions as well.

## 1.1 Target groups

These instructions are aimed at qualified personal and must be carefully read by anyone mounting, commissioning, operating, maintaining, dismantling or disposing of the device.

## 1.2 Explanation of symbols used

The following symbols are used in these instructions:



**DANGER**

DANGER indicates a dangerous situation with high risk of death or severe injury if not avoided.



**WARNING**

WARNING indicates a dangerous situation with medium risk of death or severe injury if not avoided.



**CAUTION**

CAUTION indicates a dangerous situation of medium risk which may result in minor or moderate injury if not avoided.



**NOTICE**

NOTICE indicates a situation which may lead to property damage if not avoided.



**NOTE**

NOTE indicates tips, recommendations and useful information on specific actions and facts. The notes simplify your work and help you to avoid additional work.



**CALL TO ACTION**

This symbol denotes actions that the user must carry out.



**RESULTS OF ACTION**

This symbol denotes relevant results of actions.

## 1.3 Other documents

Besides this document, the following material can be found on the Internet at [www.turck.com](http://www.turck.com):

- Data sheet
- Quick Start Guide

## 1.4 Feedback about these instructions

We make every effort to ensure that these instructions are as informative and as clear as possible. If you have any suggestions for improving the design or if some information is missing in the document, please send your suggestions to [techdoc@turck.com](mailto:techdoc@turck.com).

## 2 Information about the product

### 2.1 Product identification

These instructions apply to the following encoders with analog output:

- RES-06
- RES-07
- RES-180
- RES-181
- REM-97
- REM-98
- REM-116
- REM-E-116

### 2.2 Scope of delivery

The scope of delivery includes:

- Encoder – sensor
- Quick Start Guide

### 2.3 Turck service

Turck supports you with your projects, from initial analysis to the commissioning of your application. The Turck product database under [www.turck.com](http://www.turck.com) contains software tools for programming, configuration or commissioning, data sheets and CAD files in numerous export formats.

The contact details of Turck subsidiaries worldwide can be found on p. [▶ 18].

## 3 For your safety

The product is designed according to state-of-the-art technology. However, residual risks still exist. Observe the following warnings and safety notices to prevent damage to persons and property. Turck accepts no liability for damage caused by failure to observe these warning and safety notices.

### 3.1 Intended use

The encoders with analog output are used to measure angle movements. For this, the devices convert mechanical rotary movements into analog output signals of 4...20 mA.

The devices may only be used as described in these instructions. Any other use is not in accordance with the intended use. Turck accepts no liability for any resulting damage.

### 3.2 Obvious misuse

- The devices are not safety components and must not be used for personal or property protection.
- Any use that exceeds the maximum permissible mechanical speed (see technical data) is deemed to be not in accordance with the intended purpose.

### 3.3 General safety notes

- The device meets the EMC requirements for industrial areas. When used in residential areas, take measures to avoid radio interference.
- The device may only be assembled, installed, operated, parameterized and maintained by professionally-trained personnel.
- The device may only be used in accordance with applicable national and international regulations, standards and laws.
- If safe operation is no longer guaranteed: Take the device out of operation and ensure that it cannot be switched on again accidentally.

## 4 Product description

The encoders in the REM... and RES... product series are available as solid shaft or hollow shaft versions. The REM/RES-E-... product series contains only solid shaft devices. Devices are available in three different sizes, ranging from 36 to 100 mm.

The encoders with analog output measure angular movements. To do this, they convert mechanical movements into analog output signals of 4...20 mA.

### 4.1 Device overview



Fig. 1: Example – encoder with hollow shaft

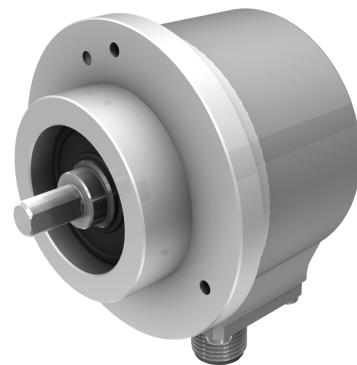

Fig. 2: Example – encoder with solid shaft

### 4.2 Operating principle

Encoders detect rotational movements, such as the angle velocity of a shaft. Encoders convert the rotational movements into electrical signals. The devices pass on the electrical signals to a higher-level controller for evaluation. Encoders are designed as absolute and incremental encoders with hollow or solid shafts.

Absolute encoders also supply the angle value after a startup if the value has changed when deactivated. Incremental encoders only detect position changes when active by counting periodic patterns. This normally involves the optical scanning of a rotating disk.



### 4.3 Functions and operating modes

#### 4.3.1 Output function

The output signal is scaled linearly within the measuring range. The encoders are available with clockwise (CW) or counterclockwise (CCW) direction of rotation. The reference point of 0...1° is indicated via the LED.

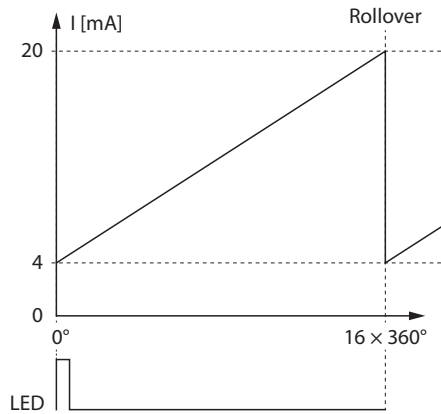

Fig. 3: Output function – CW version  
(Example: multiturn, current output)

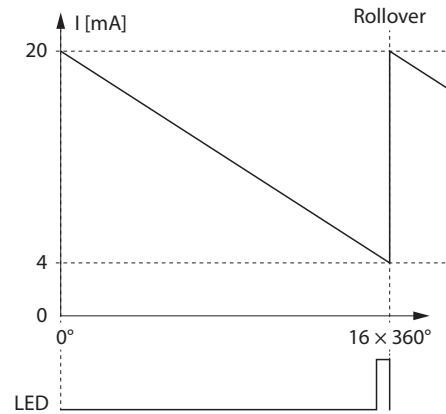

Fig. 4: Output function – CCW version  
(Example: multiturn, current output)

### 4.4 Technical accessories

Dimension drawing	Type	ID	Description
	RKC4.5T-2/TEL	6625016	Connection cable; M12 female connector, straight, 5-pin, cable length 2 m, jacket material: PVC, black; chemical and oil resistant, flame retardant, resistant to acids and alkalis, microbe and hydrolysis resistant, LABS free; cULus approved; RoHS compliant; IP67 protection; other cable lengths and types available, see <a href="http://www.turck.com">www.turck.com</a>

## 5 Installing



### NOTICE

Incorrect mounting

#### Risk of damage to the sensor

- ▶ Do not modify or disassemble the encoder.
- ▶ Do not make adjustments to the shaft after mounting.
- ▶ Do not use a hammer to align the device.
- ▶ Avoid impact loads.
- ▶ Load the encoder shaft only within the permissible values (see technical data).
- ▶ Do not rigidly connect the rotary encoder to shafts and flanges at the same time.  
Use the coupling between the drive shaft and the encoder shaft or the hollow shaft encoder flange.

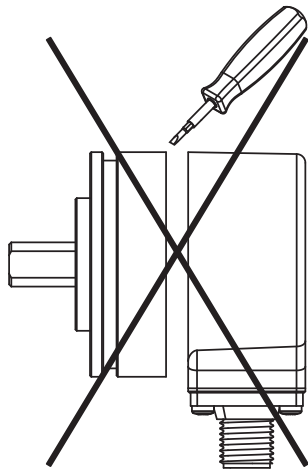

Fig. 5: Mounting view – do not open

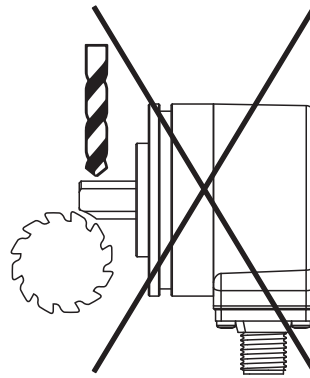

Fig. 6: Mounting view – do not make adjustments after mounting

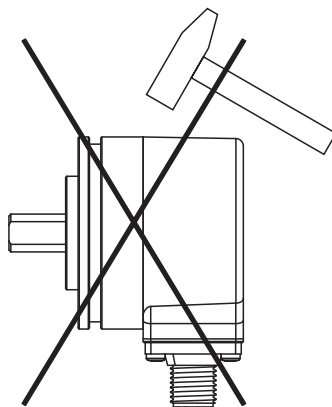

Fig. 7: Mounting view – do not use a hammer to align the device

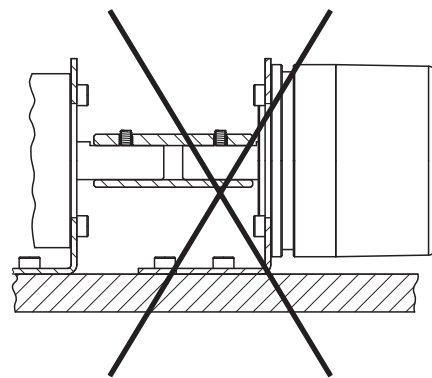

Fig. 8: Mounting view – do not rigidly connect the device to shafts and flanges at the same time

## 5.1 Mounting the solid shaft encoder using a coupling

- ▶ Check shaft for displacement.
- ▶ Refer to the technical data for the coupling for the maximum axial displacement, radial displacement, and angular displacement values.

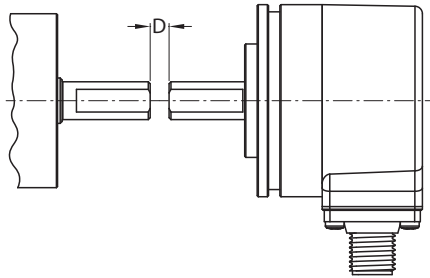

Fig. 9: Axial displacement

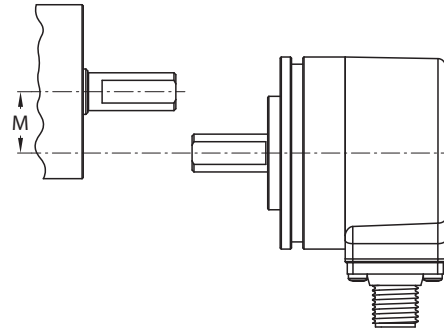

Fig. 10: Radial displacement

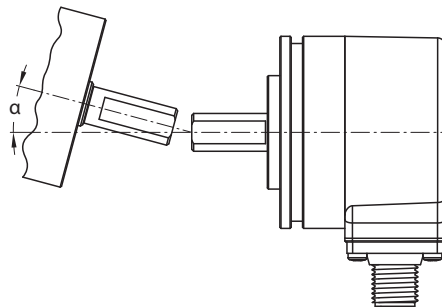

Fig. 11: Angular displacement

- ▶ During mounting, protect the coupling against excessive bending and damage.
- ▶ Align the coupling on the shaft.
- ▶ Secure the coupling on the device using tensioning screws or clamping screws. For the maximum tightening torque, refer to the data sheet of the screws used.

## 5.2 Mounting the hollow shaft encoder using a coupling

- ▶ Mount the encoder with the coupling on the shaft.

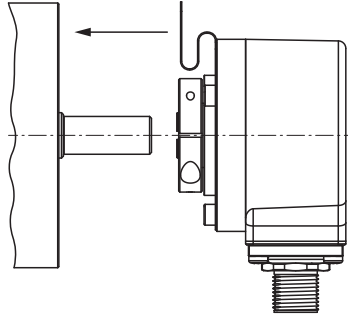

Fig. 12: Mounting on the shaft with the coupling

- ▶ Screw the coupling to the drive flange.

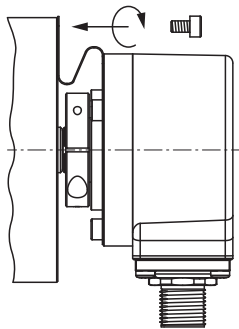

Fig. 13: Screwing the coupling to the drive flange

- ▶ Carefully tighten the clamping hub.

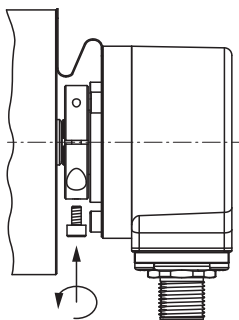

Fig. 14: Tightening the clamping hub

## 6 Connection

The encoder has a 5-pin M12 × 1 male connector with analog output. The pin assignment can be found on the sensor label or the data sheet.

Turck recommends the following cable lengths:

- For asymmetrical transmission (no inverted signals): max. 10 m
  - For symmetrical transmission (e.g. RS422 standard): max. 50 m with twisted pairs
- ▶ Connect all required cable cores as per the wiring diagram. Insulate the cable ends that are not required to avoid short circuits.
  - ▶ Follow the operating instructions for the connecting cable used.
  - ▶ Disconnect the encoder from the connecting cable only when the encoder is de-energized.
  - ▶ Connect the shielding (if present) to the encoder housing.
  - ▶ The encoder and processor must always be switched on and off simultaneously.
  - ▶ Observe the operating voltage and maximum permissible output current (see technical data).

### EMC-compliant installation

- ▶ Use shielded connection cables as control cables.
- ▶ For symmetrical transmission (e.g. via RS422): Use twisted pair cables.
- ▶ Connect protective earth to the rotary encoder and the evaluation unit (low impedance).
- ▶ Route the connection cables separately from cables with high noise levels.
- ▶ Do not connect devices with high noise levels to the encoder's power supply (e.g. frequency converters, solenoid valves, or contactors), or ensure that suitable voltage filtering is in place.

### 6.1 Wiring diagram – current output

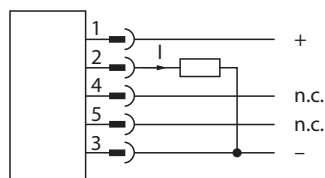

Fig. 15: Wiring diagram – current output

### 6.2 Wiring diagram – voltage output

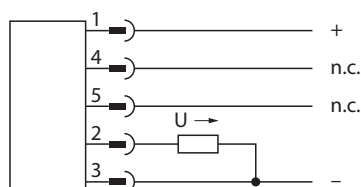

Fig. 16: Wiring diagram – voltage output

## 7 Commissioning

After connecting and switching on the power supply, the device is automatically ready for operation.

## 8 Operation

### 8.1 LED display

LED display	Meaning
Green	Device ready for operation.
Green and red	Reference point display
Flashing green (4 Hz)	Service mode Contact Turck.
Flashing red/green alternately (4 Hz)	System error internal system error Contact Turck.
Flashing red/green alternately (2 Hz)	Wire break The load on the analog output is too small. Connection to the controller is interrupted. Check wiring.
Off	Device is not ready for operation. Faulty power supply. Check power supply and wiring.

## 9 Troubleshooting

If the device does not function as expected, first check whether ambient interference is present. If there is no ambient interference present, check the connections of the device for faults.

If there are no faults, there is a device malfunction. In this case, decommission the device and replace it with a new device of the same type.



## 10 Maintenance

Ensure that the plug connections and cables are always in good condition.

The devices are maintenance-free, clean dry if required.

## 11 Repair

The device must not be repaired by the user. The device must be decommissioned if it is faulty. Observe our return acceptance conditions when returning the device to Turck.

### 11.1 Returning devices

Returns to Turck can only be accepted if the device has been equipped with a Decontamination declaration enclosed. The decontamination declaration can be downloaded from <https://www.turck.de/en/retoure-service-6079.php> and must be completely filled in, and affixed securely and weather-proof to the outside of the packaging.

## 12 Disposal



The devices must be disposed of correctly and must not be included in general household garbage.

## 13 Turck subsidiaries – contact information

<b>Germany</b>	Hans Turck GmbH & Co. KG Witzlebenstraße 7, 45472 Mülheim an der Ruhr <a href="http://www.turck.de">www.turck.de</a>
<b>Australia</b>	Turck Australia Pty Ltd Building 4, 19-25 Duerdin Street, Notting Hill, 3168 Victoria <a href="http://www.turck.com.au">www.turck.com.au</a>
<b>Belgium</b>	TURCK MULTIPROX Lion d'Orweg 12, B-9300 Aalst <a href="http://www.multiprox.be">www.multiprox.be</a>
<b>Brazil</b>	Turck do Brasil Automação Ltda. Rua Anjo Custódio Nr. 42, Jardim Anália Franco, CEP 03358-040 São Paulo <a href="http://www.turck.com.br">www.turck.com.br</a>
<b>China</b>	Turck (Tianjin) Sensor Co. Ltd. 18,4th Xinghuazhi Road, Xiqing Economic Development Area, 300381 Tianjin <a href="http://www.turck.com.cn">www.turck.com.cn</a>
<b>France</b>	TURCK BANNER S.A.S. 11 rue de Courtalin Bat C, Magny Le Hongre, F-77703 MARNE LA VALLEE Cedex 4 <a href="http://www.turckbanner.fr">www.turckbanner.fr</a>
<b>Great Britain</b>	TURCK BANNER LIMITED Blenheim House, Hurricane Way, GB-SS11 8YT Wickford, Essex <a href="http://www.turckbanner.co.uk">www.turckbanner.co.uk</a>
<b>India</b>	TURCK India Automation Pvt. Ltd. 401-403 Aurum Avenue, Survey. No 109 /4, Near Cummins Complex, Baner-Balewadi Link Rd., 411045 Pune - Maharashtra <a href="http://www.turck.co.in">www.turck.co.in</a>
<b>Italy</b>	TURCK BANNER S.R.L. Via San Domenico 5, IT-20008 Bareggio (MI) <a href="http://www.turckbanner.it">www.turckbanner.it</a>
<b>Japan</b>	TURCK Japan Corporation Syuuhou Bldg. 6F, 2-13-12, Kanda-Sudacho, Chiyoda-ku, 101-0041 Tokyo <a href="http://www.turck.jp">www.turck.jp</a>
<b>Canada</b>	Turck Canada Inc. 140 Duffield Drive, CDN-Markham, Ontario L6G 1B5 <a href="http://www.turck.ca">www.turck.ca</a>
<b>Korea</b>	Turck Korea Co, Ltd. B-509 Gwangmyeong Technopark, 60 Haan-ro, Gwangmyeong-si, 14322 Gyeonggi-Do <a href="http://www.turck.kr">www.turck.kr</a>
<b>Malaysia</b>	Turck Banner Malaysia Sdn Bhd Unit A-23A-08, Tower A, Pinnacle Petaling Jaya, Jalan Utara C, 46200 Petaling Jaya Selangor <a href="http://www.turckbanner.my">www.turckbanner.my</a>

<b>Mexico</b>	Turck Comercial, S. de RL de CV Blvd. Campestre No. 100, Parque Industrial SERVER, C.P. 25350 Arteaga, Coahuila <a href="http://www.turck.com.mx">www.turck.com.mx</a>
<b>Netherlands</b>	Turck B. V. Ruiterlaan 7, NL-8019 BN Zwolle <a href="http://www.turck.nl">www.turck.nl</a>
<b>Austria</b>	Turck GmbH Graumanngasse 7/A5-1, A-1150 Wien <a href="http://www.turck.at">www.turck.at</a>
<b>Poland</b>	TURCK sp.z.o.o. Wroclawska 115, PL-45-836 Opole <a href="http://www.turck.pl">www.turck.pl</a>
<b>Romania</b>	Turck Automation Romania SRL Str. Siriului nr. 6-8, Sector 1, RO-014354 Bucuresti <a href="http://www.turck.ro">www.turck.ro</a>
<b>Russian Federation</b>	TURCK RUS OOO 2-nd Pryadilnaya Street, 1, 105037 Moscow <a href="http://www.turck.ru">www.turck.ru</a>
<b>Sweden</b>	Turck Sweden Office Fabriksstråket 9, 433 76 Jonsered <a href="http://www.turck.se">www.turck.se</a>
<b>Singapore</b>	TURCK BANNER Singapore Pte. Ltd. 25 International Business Park, #04-75/77 (West Wing) German Centre, 609916 Singapore <a href="http://www.turckbanner.sg">www.turckbanner.sg</a>
<b>South Africa</b>	Turck Banner (Pty) Ltd Boeing Road East, Bedfordview, ZA-2007 Johannesburg <a href="http://www.turckbanner.co.za">www.turckbanner.co.za</a>
<b>Czech Republic</b>	TURCK s.r.o. Na Brne 2065, CZ-500 06 Hradec Králové <a href="http://www.turck.cz">www.turck.cz</a>
<b>Turkey</b>	Turck Otomasyon Ticaret Limited Sirketi Inönü mah. Kayisdagi c., Yesil Konak Evleri No: 178, A Blok D:4, 34755 Kadiköy/ Istanbul <a href="http://www.turck.com.tr">www.turck.com.tr</a>
<b>Hungary</b>	TURCK Hungary kft. Árpád fejedelem útja 26-28., Óbuda Gate, 2. em., H-1023 Budapest <a href="http://www.turck.hu">www.turck.hu</a>
<b>USA</b>	Turck Inc. 3000 Campus Drive, USA-MN 55441 Minneapolis <a href="http://www.turck.us">www.turck.us</a>

# TURCK

Over 30 subsidiaries and over  
60 representations worldwide!

100009120 | 2022/04



[www.turck.com](http://www.turck.com)