

TURCK

Industrial
Automation

**USER MANUAL
BL IDENT-
HANDHELD
HARDWARE**

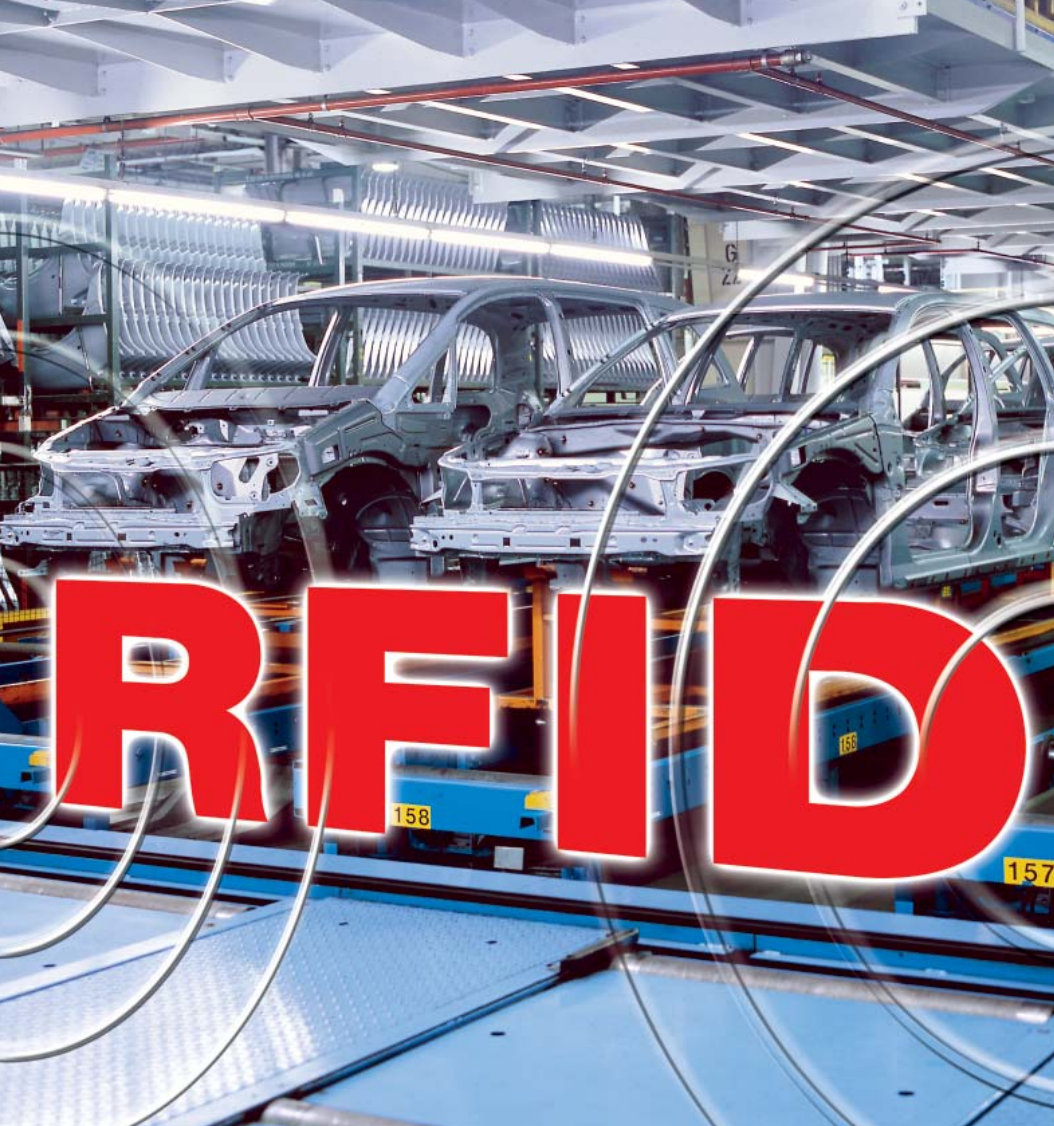

Technical Reference Manual

BL ident-Handheld TURCK-RFID-Handheld-Computer Version 1.0

Hans Turck GmbH & Co.KG



Regulatory Notices

FCC Part 15 Class A

This equipment has been tested and found to comply with the limits for a Class A digital device, pursuant to Part 15 of the FCC Rules. These limits are designed to provide reasonable protection against harmful interference when the equipment is operated in a commercial environment. This equipment generates, uses, and can radiate radio frequency energy and, if not installed and used in accordance with the instruction manual, may cause harmful interference to radio communications. Operation of this equipment in a residential area is likely to cause harmful interference in which case the user will be required to correct the interference at his own expense.

FCC Part 15.225 (15C)

Registration Number: RYJJETTRFID-1356

Canadian Department of Communications

This digital apparatus does not exceed the Class A limits for radio noise emissions from digital apparatus set out in the Radio Interference Regulations of the Canadian Department of Communications

Le present appareil numerique n'émet pas de bruits radioelectrique dépassant les limites applicables aux appareils numeriques de la class A prescrites dans le Reglement sur le brouillage radioelectrique edicte par le ministere des Communications du Canada.

Industry Canada RSS-210 6.2.2(e), 2001

Certifications

CENELEC



EMI Standards:

- EN 55022:1998 (CISPR22), Class A
- EN 55022/IEC 61000-4-6
- ETSI EN 300 330-2: 2001

EMC Standards:

- EN 55024: 1998
- ETSI EN 301489-1: 2002
- ETSI EN 301489-3: 2002
- ~ EN/IEC 61000-4-2
- ~ EN/IEC 61000-4-3
- ~ EN/IEC 61000-4-4

Safety Standards:

- EN 60950: 2000

Warnings

Changes or modifications to this unit not expressly approved by the party responsible for regulatory compliance could void the user's authority to operate the equipment.



Operation

Do not enable or utilize the RFID module while charging the unit. Operation of this nature is likely to cause harmful interference.

Ne permettez pas ou n'utilisez pas le module de RFID tout en chargeant l'unité. L'opération de cette nature est susceptible de causer l'interférence nocive.

No permita ni utilice el módulo de RFID mientras que carga la unidad. La operación de esta naturaleza es probable causar interferencia dañosa.

Lassen Sie das RFID-Modul während des Aufladens des Geräts uneingeschaltet. Ein Betrieb während des Aufladens verursacht mit großer Wahrscheinlichkeit schädliche Störungen.



Electrostatic Discharge (ESD)

Electrostatic discharge (static electricity) can have unpredictable adverse effects on any electronic device. Although the design of this product incorporates extensive ESD-related precautions, ESD can still cause problems. It is good practice to discharge static by touching a grounded metal object before inserting cards or connecting devices.

La descarga electrostática (electricidad estática) puede tener efectos nocivos imprevisibles en cualquier dispositivo electrónico. Aunque el diseño de este producto incorpora precauciones ESD-relacionadas extensas, la lata de ESD todavía causa problemas. Es buena práctica descargar parásitos atmosféricos tocando un objeto puesto a tierra del metal antes de insertar tarjetas o de conectar los dispositivos.

La décharge électrostatique (l'électricité statique) peut avoir des effets nuisibles imprévisibles sur n'importe quel dispositif électronique. Bien que la conception de ce produit incorpore des précautions ESD-connexes étendues, le bidon d'ESD posent toujours des problèmes. Il est dans de bons habitudes de décharger la charge statique en touchant un objet au sol en métal avant d'insérer des cartes ou relier des dispositifs.

Elektrostatische Entladung (statische Elektrizität) kann unvorhersehbare schädliche Wirkungen auf elektronische Geräte haben. Obwohl das Gerät mit verschiedenen und umfangreichen ESD-bezogenen Schutzmaßnahmen versehen ist, kann es doch zu ESD-Problemen kommen. Sorgen Sie vor dem Einsetzen von Karten oder dem Anschluss von Geräten durch Berühren eines geerdeten Metallgegenstands immer für eine statische Entladung.



Battery Replacement

CAUTION! There is a risk of explosion if you replace the NiMH battery with an incorrect type. Only use the NiMH battery supplied with your unit or a replacement NiMH battery supplied, recommended, or approved by TURCK, Inc.

PRECAUCIÓN! Hay un riesgo de la explosión si usted substituye la batería de NiMH por un tipo incorrecto. Utilice solamente la batería de NiMH provista de su unidad o una batería de NiMH del reemplazo provista, recomendada, o aprobada por TURCK, Inc.

ATTENTION! Il y a un risque d'explosion si vous remplacez la batterie de NiMH avec un type incorrect. Utilisez seulement la batterie de NiMH fournie avec votre unité ou une batterie de NiMH de remplacement fournie, recommandée, ou approuvée par TURCK, Inc.

VORSICHT! Bei Verwendung von NiMH-Batterien, die nicht von TURCK, Inc. geliefert, empfohlen oder genehmigt wurden, besteht Explosionsgefahr! Benutzen Sie daher nur solche NiMH-Batterien, die mit dem Gerät geliefert wurden, oder Batterien, die von TURCK, geliefert, empfohlen oder genehmigt wurden.



Battery Disposal

Dispose of batteries in a safe manner. The following are general guidelines for the safe use and disposal of NiMH batteries:

Replace a defective NiMH battery immediately as it could damage the unit.

Do not throw the NiMH battery in trash that is disposed of in landfills as it contains heavy metals. Recycle or dispose the NiMH battery of it as required by local ordinances or regulations.

Do not disassemble, incinerate, short-circuit the NiMH battery or throw it into a fire. It can explode and cause severe personal injury.

Excessive discharge damages a NiMH battery. Recharge the NiMH battery when your unit indicates low battery power.

Disponga de las baterías de una manera segura. Los siguientes son pautas generales para el uso seguro y la disposición de las baterías de NiMH:

Substituya una batería defectuosa de NiMH inmediatamente pues podría dañar la unidad.

No lance la batería de NiMH en la basura que se dispone en terraplenes mientras que contiene los metales pesados. Recicle o disponga la batería de NiMH de ella según los requisitos de ordenanzas o de regulaciones locales.

No desmonte, no incinere, no cortocircuitos la batería de NiMH ni láncela en un fuego. Puede estallar y causar daños corporales severos.

La descarga excesiva daña una batería de NiMH. Recargue la batería de NiMH cuando su unidad indica energía de batería baja.

Débarassez-vous des batteries d'une façon sûre. Ce qui suit sont les orientations à l'utilisation sûre et à la disposition des batteries de NiMH:

Remplacez une batterie défectueuse de NiMH immédiatement car elle pourrait endommager l'unité.

Ne jetez pas la batterie de NiMH dans le débris qui est déposé en remblais pendant qu'il contient les métaux lourds. Réutilisez ou disposez la batterie de NiMH d'elle selon les exigences des ordonnances ou des règlements locaux.

Ne démontez pas, n'incinerez pas, ne court-circuitiez pas la batterie de NiMH ou ne la jetez pas dans un feu. Il peut éclater et causer des blessures graves.

La décharge excessive endommage une batterie de NiMH. Rechargez la batterie de NiMH quand votre unité indique la basse puissance de batterie.

Entsorgen Sie die Batterien auf eine sichere Weise. Die folgenden Regeln sind allgemeine Richtlinien für den sicheren Gebrauch und die sichere Entsorgung der NiMH-Batterien:

Ersetzen Sie eine defekte NiMH Batterie sofort, da sie das Gerät beschädigen könnte.

Die NiMH-Batterien enthalten Schwermetalle. Werfen Sie die Batterien daher nicht in den Hausmüll, der in normalen Deponien abgeladen wird, sondern entsorgen Sie sie gemäß den geltenden lokalen Vorschriften für Sondermüll.

Bauen Sie die Batterien nicht auseinander, zünden Sie sie nicht an, schließen Sie sie nicht kurz und werfen Sie diese nichts ins Feuer. Sie können explodieren und ernste Verletzungen verursachen.

Eine übermäßige Entladung beschädigt eine NiMH-Batterie. Laden Sie die NiMH-Batterie neu, wenn auf dem Geräte eine niedrige Batterieleistung angezeigt wird.



Servicing Information

When servicing the unit, the plug (*BL ident* connect cable) is the disconnect device. Simply unplug the unit before servicing.

Al mantener la unidad, el enchufe (cable de *BL ident* connect) es el dispositivo de la desconexión. Desenchufe simplemente la unidad antes de mantener.

En entretenant l'unité, la prise (câble de *BL ident* connect) est le dispositif de débranchement. Débranchez simplement l'unité avant l'entretien.

Vor der Wartung des Geräts ist der Stecker (*BL ident*-Anschlussleitung) zu ziehen..

Contents

Chapter 1: Overview	1-1
About this Manual	1-1
About RFID	1-1
About the <i>BL ident</i> -Handheld	1-2
<i>BL ident</i> -Handheld Features	1-2
Chapter 2: Getting Started	2-1
Front Components and Indicators	2-1
Rear Components	2-2
Compact Flash Slot Cover	2-3
Interface Connections	2-4
<i>BL ident</i> connect system.....	2-4
DE-9 Connectors.....	2-4
6-Pin Modular Connector	2-5
Power Jack.....	2-5
Power Supplies, Cables and Adapters	2-5
Chapter 3: Operation	3-1
Power	3-1
Charging the Unit.....	3-1
Charge/Low Battery Indicator	3-2
Power/Suspend Switch.....	3-3
Power Management.....	3-4
Replacing Batteries/Battery Pack.....	3-5
Data Entry	3-6
Keypads	3-6
CE Keyboard	3-7
Using the RFID Module	3-8
The Windows CE .NET Desktop	3-9
Desktop Functions	3-9
The Taskbar.....	3-9
The Start Menu	3-10
SystemCF Folder	3-10
Chapter 4: Configuration	4-1
The Control Panel.....	4-1
Changing System Settings.....	4-3
Taskbar and Start Menu Settings	4-4
Using the Compact Flash Slot.....	4-5
Network Connections	4-6
Creating a Wired Ethernet Network Connection.....	4-6
Creating Network Connection using a WLAN 802.11b Card	4-6
Setting Up Identification for Remote Networks	4-7
Connecting to a Mail Server.....	4-7
ActiveSync.....	4-9
Initial Communication.....	4-9
Subsequent Communication.....	4-12
Persistent Registry.....	4-12
Saving Changes to the Registry.....	4-12
Resetting the Registry	4-13
Chapter 5: Troubleshooting	5-1
Appendix A: Specifications	A-1
Appendix B: Signal and Pin Assignments	B-1
<i>BL ident</i> connect Cables.....	B-1
1210 Series Modular Interface Cables.....	B-2
Modular Cable Adapters.....	B-3
Null Modem Cable	B-3

Appendix C: Keyboard Mapping Files	C-1
Keyboard Mapping Files Notes	C-1
45-Key Key Map	C-2
30-Key Key Map	C-3
15-Key Key Map	C-4
Index	I-1

List of Tables

Table 1-1: Tag Compatibility Chart	1-2
Table 2-1: Front Components and Indicators	2-1
Table 2-2: Rear Components.....	2-2
Table 2-3: Available Power Supplies, Cables and Adapters.....	2-5
Table 3-1: Charge\Low Battery Indicator Functions.....	3-2
Table 3-2: Modifier Key Actions	3-7
Table 3-3: Desktop Functions	3-9
Table 3-4: Power Status Icons	3-10
Table 4-1: Control Panel Functions.....	4-1
Table 7-1: Allowed Values in Key Map Files.....	C-1

List of Figures

Figure 2-1: Front Components and Indicators	2-1
Figure 2-2: Rear Components.....	2-2
Figure 2-3: Standard Compact Flash Slot Cover in Closed Position	2-3
Figure 2-4: Standard Compact Flash Slot Cover in Open Position.....	2-3
Figure 2-5: Modified Compact Flash Slot Cover for Long Device Cards	2-3
Figure 2-6: Sealed Compact Flash Slot Cover.....	2-3
Figure 2-7: <i>BL ident</i> connect Interface Connector	2-4
Figure 2-8: DE-9 Male Interface Connector	2-4
Figure 2-9: DE-9 Female Interface Connector.....	2-4
Figure 2-10: 6-Pin Modular Interface Connector.....	2-5
Figure 2-11: Power Jack.....	2-5
Figure 3-1: Using 91708, 91709, and 14375 Cables	3-1
Figure 3-2: Using 1210 Series Cables	3-1
Figure 3-3: Power Supply.....	3-2
Figure 3-4: Charge/Low Battery Indicator.....	3-2
Figure 3-5: Power/Suspend Switch.....	3-3
Figure 3-6: Changing Batteries	3-5
Figure 3-7: Standard Keypad Layouts.....	3-6
Figure 3-8: 45-Keypad Multifunctional Key	3-6
Figure 3-9: CE Keyboard	3-7
Figure 3-10: RFID Read Range	3-8
Figure 3-11: Windows CE .NET Desktop.....	3-9
Figure 3-12: Windows CE .NET Desktop Taskbar.....	3-9
Figure 3-13: Start Menu	3-10
Figure 6-1: Case Dimensions	A-2
Figure 6-2: 91708 Cable (Male DE9) RS-232 Signal and Pin Assignments	B-1
Figure 6-3: 91709 Cable (Female DE9) RS-232 Signal and Pin Assignments	B-2
Figure 6-4: 1210 Series Modular Cable Signal and Pin Assignments	B-2
Figure 6-5: CELAT-P Adapter	B-3
Figure 6-6: DE-9 Female to DE-9 Female Null Modem Cable.....	B-3

Chapter 1: Overview

About this Manual

Intended for authorized developers with prior knowledge of Windows CE .NET and hand held PC application development using eMbedded Visual C++ and Visual Studio .NET, this manual describes the advanced features, operations and interface capabilities of TURCK' BL ident-Handheld. It is not for use by end-users.

Because the *BL ident-Handheld* is a highly customizable product with many optional configurations and special keypad layouts, this manual only describes the standard features and operation of the *BL ident-Handheld*. For custom configurations and special options, consult the appropriate supplemental manual or addendum.

Unless otherwise stated, the operational characteristics described herein correspond to factory default configurations and settings as shipped from TURCK. Wherever used herein, the term "*BL ident-Handheld*" applies to all models (except as noted).

It is beyond the scope of this manual to provide operating system tutorials or information about commercial or customized *BL ident-Handheld* application programs and connected equipment. This information should be available in the manuals that accompany those products.

About RFID

RFID (Radio Frequency Identification) is a wireless communication technology that uses the RF portion of the electromagnetic spectrum to transmit and receive information from EPC (Electronic Product Code) tags. The tags can come in many shapes and sizes, such as disks, cards or paper labels (smart labels) and can store a simple identification number or a sophisticated database.

RFID technology is based on the simple idea that a reader can activate an electronic circuit inside a tag from a distance and exchange information. An integrated circuit inside the reader creates an alternating current. This current generates an alternating magnetic field through the reader's antenna that serves as a power source for a RFID tag. This magnetic field interacts with the antenna in the tag, which in turn, activates the tag's integrated circuit causing the tag to create a digital signal, which contains an encoded identifier number.

The tag then generates its own alternating magnetic field, which interacts with the reader's alternating magnetic field. A device inside the RFID reader senses the variations and converts this pattern to the digital signal, which interprets the tag's identifier code.

About the *BL ident*-Handheld

With its modern, ergonomic appearance and design, the *BL ident*-Handheld is the most recent addition to TURCK' series of rugged hand held computers for industrial and commercial use. Its quick mount connector system allows easy insertion and removal in cradle or vehicle mounts.

Designed for one-handed operation, the *BL ident*-Handheld features a powerful Microsoft Windows CE .NET 4.2 operating system, Intel XScale Technology Processor, color sunlight readable display with touch screen technology.

With its powerful 13.56 MHz RFID integrated reader and flip-out antenna, the *BL ident*-Handheld can read and write most industry standard RFID tags within a 3.5 inch (80 mm) range making it ideal for "contactless" payments, item tracking and data collection.

BL ident – Handheld Features

Rechargeable Battery Pack

The *BL ident*-Handheld comes with a rechargeable Nickel Metal Hydride (NiMH) battery pack that can provide up to twelve hours of operating time on a full charge (depending on power management and use). The NiMH technology used in the *BL ident*-Handheld has exceptional charge life without the "charge memory" characteristic of conventional nickel cadmium batteries. Partially discharged batteries or extended periods with the charger left connected will not adversely affect battery life or performance. The *BL ident*-Handheld can also run on six AA Alkaline batteries.

Operating System

The *BL ident*-Handheld uses Windows CE .NET Professional 4.2 as its operating system

Processor

The *BL ident*-Handheld utilizes an Intel PXA255 processor with XScale technology at 200MHz (400MHz optional) .The Intel PXA255 processor is a highly integrated, 32-bit RISC processor that combines the efficiency of Intel design with the ARM v.5TE instruction set architecture.

Memory and Mass Storage

The *BL ident*-Handheld comes standard with 64MB of SDRAM and 64MB (approximately 16MB used for operating system) of internal compact flash memory, which is expandable to 128MB. For removable data storage or I/O cards, the *BL ident*-Handheld is equipped with a Compact Flash (CF) slot.

Displays

The *BL ident-Handheld* features a supertwist nematic liquid crystal 320 × 240 QVGA-TFT color sunlight readable display with options for a touch screen and LED backlight.

Keypads

Standard keypad configurations for the *BL ident-Handheld* include 15-key, 30-key, and 45-key elastomeric keypads and a 45-key membrane keypad. All standard keypad configurations have an option for LED backlighting.

Indicators

The *BL ident-Handheld* has five programmable LED indicators that can provide a number of useful functions including the state of keypad modifier keys. An additional LED indicates the charge and low battery statuses.

Interface Capabilities

The *BL ident-Handheld* comes standard with one available serial port configured for RS-232.

Durability

The case is made of General Electric Xenoy, one of the most durable chemical resistant materials available today.

Chapter 2: Getting Started

Front Components and Indicators

This section describes the components and indicators found on the front of the *BL ident-Handheld*.

Figure 2-1: Front Components and Indicators

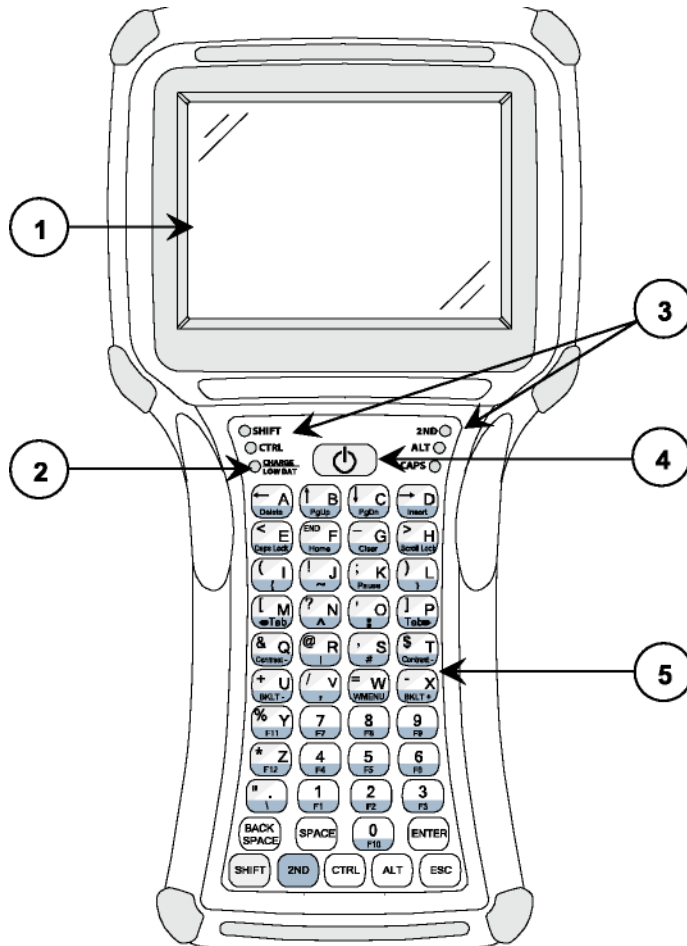

Table 2-1: Front Components and Indicators

<i>Item</i>	<i>Function</i>	<i>Description</i>
1	Display	Supertwist nematic liquid crystal display with touch screen
2	Battery Indicator	Indicates low battery (red) status and charging (green) status
3	LEDs	Indicates use of the SHIFT, CTRL, 2ND ALT and CAPS modifier keys
4	On/Off Switch	Controls the Power, Suspend and Resume operations
5	Keypad	Standard 45-key keypad (30 and 15-key keypads not shown)

Rear Components

This section describes the components found on the rear of the *BL ident*-Handheld.

Figure 2-2: Rear Components

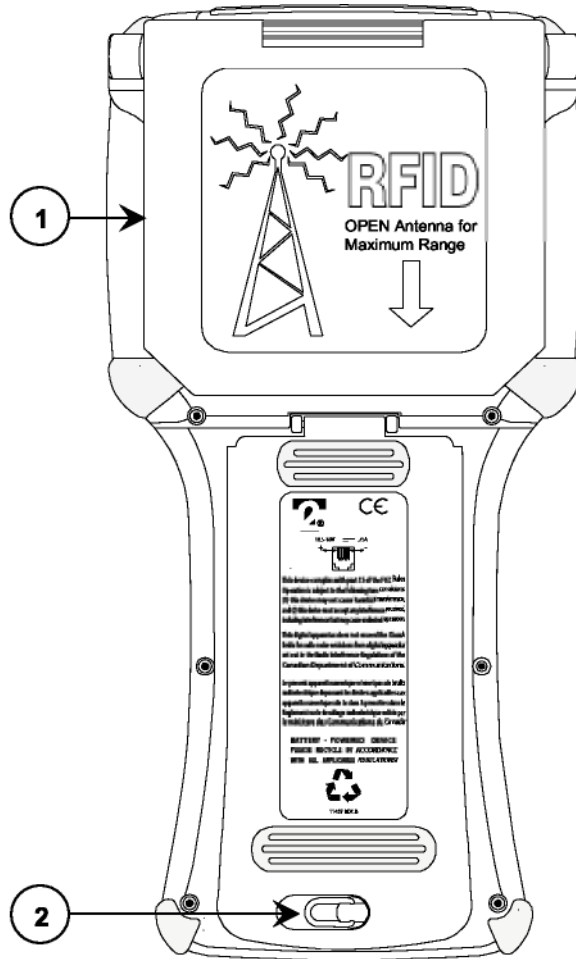

Table 2-2: Rear Components

Item	Function	Description
1	RFID Module	The RFID Module attached to the rear of the unit can read RFID tags in its storage position (show above) or swing out up to 180 degrees for maximum range. See Figure 3-10 .
2	Battery Compartment	The battery compartment can store either the Nickel Metal Hydride rechargeable battery pack or six AA Alkaline batteries. You can access the battery compartment by lifting up and turning the retaining clip. For more information using batteries, see Battery-Powered Operation .

Compact Flash Slot Cover

The standard compact flash slot cover located on the top of the unit provides access to the compact flash slot that stores memory and device cards. In addition to the standard cover, a modified cover and a sealed cover are also available.

The modified cover (Figure 2-5) has a machined opening that allows you to easily insert and remove device cards that exceed 1.437 inches in height.

To remove the Torx screws requires an IP6 Torx (T6) driver.

For more information about inserting and removing memory and device cards, see [Inserting and Removing Cards](#).

Figure 2-3: Standard Compact Flash Slot Cover in Closed Position

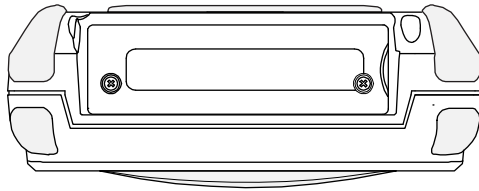

Figure 2-4: Standard Compact Flash Slot Cover in Open Position

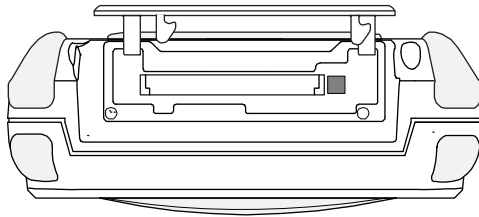
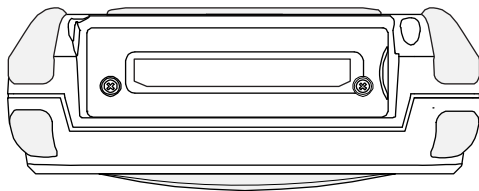

Figure 2-5: Modified Compact Flash Slot Cover for Long Device Cards



Interface Connections

This section describes the interface connectors found on the bottom of the *BL ident-Handheld*.

DE-9 Connectors

The DE-9 connectors emulate standard serial pin-out connections, and allow you to connect the *BL ident-Handheld* to most desktop PCs using a standard null modem cable.

Figure 2-8: DE-9 Male Interface Connector

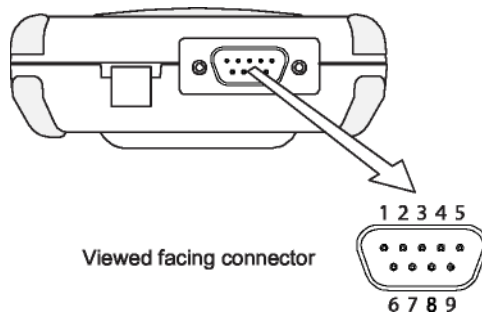

<i>RS-232 Interface Pin-Outs</i>	
Pin 1 = DCD	Pin 6 = DSR
Pin 2 = RXD	Pin 7 = RTS
Pin 3 = TXD	Pin 8 = CTS
Pin 4 = DTR	Pin 9 = 11-18VDC Input
Pin 5 = Ground	

Figure 2-9: DE-9 Female Interface Connector

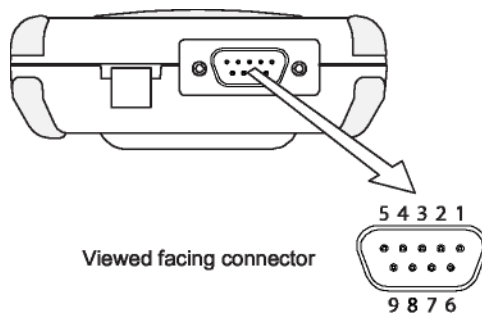

<i>RS-232 Interface Pin-Outs</i>	
Pin 1 = DTR	Pin 6 = DTR
Pin 2 = TXD	Pin 7 = CTS
Pin 3 = RXD	Pin 8 = RTS
Pin 4 = DSR/DCD	Pin 9 = 11-18VDC Input
Pin 5 = Ground	

6-Pin Modular Connector

Despite its physical similarity to a telephone jack, the 6-pin modular connector is **not** compatible with telephone lines or signals. Connecting the *BL ident*-Handheld to a telephone line will damage it and void the warranty.

Figure 2-10: 6-Pin Modular Interface Connector

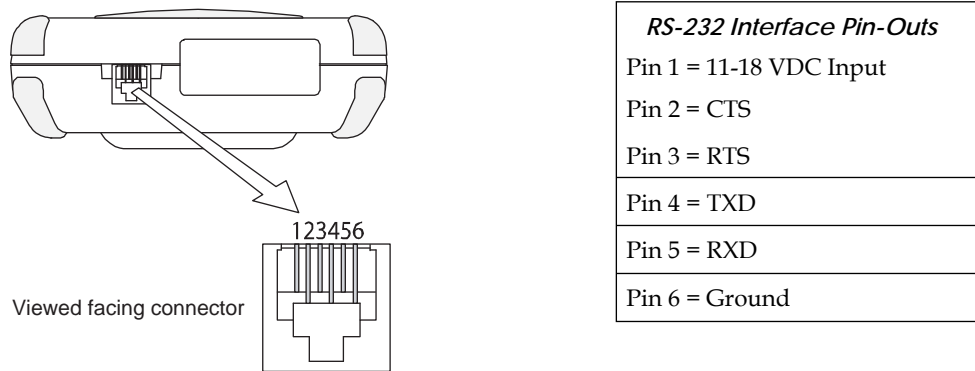

Power Jack

The optional power jack found on the bottom of the *BL ident*-Handheld enables you to connect an 11-18 VDC Input power supply battery charger, such as TURCK #14508. Use of other power supplies unless approved by TURCK may cause damage to the unit and void the warranty.

Figure 2-11: Power Jack

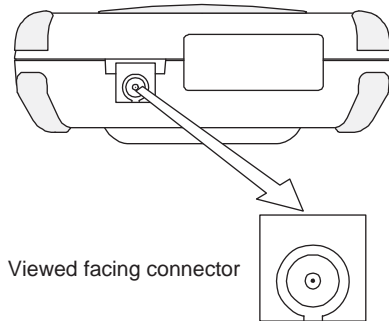

Power Supplies, Cables and Adapters

TURCK can provide the following optional power supplies, cable and adapters based on communication and power requirements. For cable signal and pin assignments, see [Appendix B: Signal and Pin Assignments](#).

Table 2-3: Available Power Supplies, Cables and Adapters

<i>TURCK Part Number</i>	<i>Part Description</i>
14508	11-18VDC Power Supply (North America Only) ¹
91708	Black, 15-Foot BL ident connect Cable (DE-9 Male)
91709	Black, 15-Foot BL ident connect Cable (DE-9 Female)
1210-7-BK	Black, 7-Foot Coiled Modular-to-Modular Cable
1210-15-BK	Black, 15-Foot Coiled Modular-to-Modular Cable
14375	Black, 15-Foot Null Modem Cable (DE9 Female to DE9 Female)
CELAT-P	Modular Cable to DE-9 Cable Adapter

1. Use of other power supplies unless approved by TURCK may cause damage to the unit and void the warranty.

Chapter 3: Operation

Power

The *BL ident*-Handheld comes with a rechargeable Nickel Metal Hydride (NiMH) battery pack that can provide up to twelve hours of operating time on a full charge (depending on power management and use). This battery is fully charged and installed in the unit when shipped. However, because some battery dissipation occurs between the time when the unit ships and when you start using it, you should charge the unit for approximately four hours before using it without the battery charger/power supply connected.

Charging the Unit

The nickel metal hydride battery technology used in the *BL ident*-Handheld has exceptional charge life without the “charge memory” characteristic of conventional nickel cadmium batteries. Partially discharged batteries or extended periods with the charger left connected will not adversely affect battery life or performance.

Warning! Do not enable or utilize the RFID module while charging the unit. Operation of this nature is likely to cause harmful interference.

Note: Because the internal battery charger senses several conditions, including temperature, you should charge the unit away from any known or potential heat sources. Units exposed to temperatures in excess of 110 degrees Fahrenheit during the charge cycle may experience incomplete charging and reduced operating time per charge.

To charge the NiMH battery pack:

1. Depending on your configuration, plug the power jack of the battery charger/power supply into the corresponding cables connector and/or adaptors as shown below.

Figure 3-1: Using 91708, 91709, and 14375 Cables

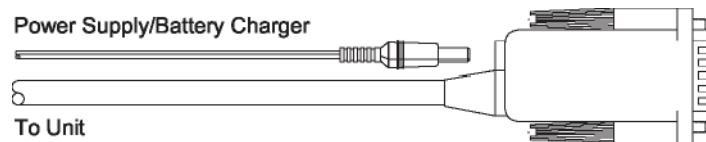
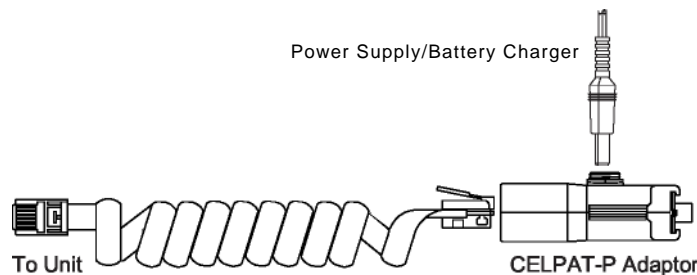
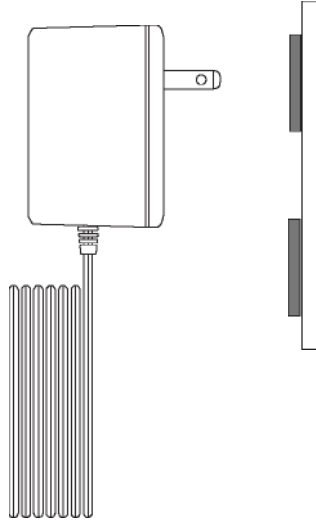

Figure 3-2: Using 1210 Series Cables



2. Plug the interface cable into the connector on the bottom of the *BL ident-Handheld*. If your unit has a power jack receptacle on the bottom of your *BL ident-Handheld*, just plug the power jack into that receptacle.
3. Plug the battery charger/power supply into a power outlet. The Charge LED should turn on, indicating that the batteries are charging (see [Table 3-1](#)).

Figure 3-3: Power Supply



4. Once the battery is fully charged (approximately four hours), you can disconnect the A power supply and run the *BL ident-Handheld* exclusively on battery power.

Charge/Low Battery Indicator

When using the NiMH battery pack, the CHARGE/LOW BAT LED will indicate the current battery status as shown in the table below.

Figure 3-4: Charge/Low Battery Indicator



Table 3-1: Charge\Low Battery Indicator Functions

<i>Function</i>	<i>Description</i>
CHARGE	<p>With the power supply connected, the CHARGE/LOW BAT LED will indicate one of following conditions:</p> <ul style="list-style-type: none"> ~ High Power Charge – the LED will turn solid green ~ Fully/Near Full Charge – the LED will blink green about four times a second ~ Trickle Charge – the LED will blink green approximately once per second when either the battery voltage and/or temperature of the battery assembly are not within acceptable limits
LOW BAT	<p>With the power supply disconnected, the CHARGE/LOW BAT LED will indicate one of following conditions:</p> <ul style="list-style-type: none"> ~ Batteries are low – the CHARGE/LOW BAT LED will blink red once per second when there is approximately 60 minutes of power remaining ~ Batteries are very low – the CHARGE/LOW BAT LED will turn solid red when there is approximately 10 minutes of power is remaining

Power/Suspend Switch

The On/Off switch is located above the keypad. Its function depends on the state of the *BL ident-Handheld* at the time the switch is pressed and on the length of time that the switch is depressed. Operations that the Power switch can initiate are:

- Power On
- Power Off
- Suspend

Figure 3-5: Power/Suspend Switch



Power On

To power on the *BL ident-Handheld*:

5. Press and hold the ON/OFF switch for one second.
6. The unit should turn on and begin displaying the boot-up process.
7. After approximately 20-25 seconds, the Windows CE .NET desktop should appear.

However, because there is no outward indication (such as a flashing LED) that the *BL ident-Handheld* is powered off or in Suspend mode, the *BL ident-Handheld* may resume an active application if it is indeed in a suspended state.

If the unit does not power up or you cannot select any items from the desktop, refer to the “[Troubleshooting](#)” chapter for help.

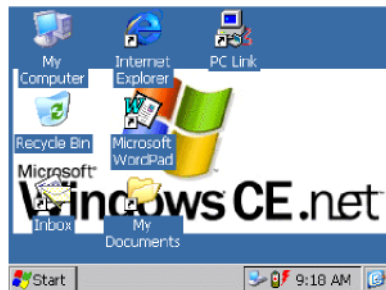

Power Off

To turn off the *BL ident-Handheld*, press and hold the ON/Off switch for approximately eight seconds. This action will also terminate running applications and cease serial port operations).

Suspend Mode

Suspend mode allows you to suspend, but not terminate active applications. In this mode, the display will turn off and the *BL ident-Handheld* will cease serial port operations. For battery-powered units, use of Suspend mode also conserves battery power.

To place the unit in Suspend mode, press and release the ON/Off switch.

To take the *BL ident-Handheld* out of Suspend mode, either touch the screen or press and release any key. The display will turn on and the *BL ident-Handheld* will resume running any suspended application, but you must restart any serial port operations.

If you attempt to resume immediately after suspending the *BL ident-Handheld* or vice versa, the unit will automatically delay three seconds before resuming or suspending.

Power Management

Battery-powered units can utilize a rechargeable Nickel Metal Hydride (NiMH) battery pack that has an average operating time between ten and twelve hours on a full charge with power management and approximately eight hours without power management. As with all battery-powered devices, the operating time is completely dependent on the environment, device usage and the number and type of power-drawing peripherals attached. The battery discharge rate in a full "Power Off" state is only slightly higher to the self-discharge rate of the battery itself.

Note: Allowing the batteries to remain in a low or very low condition will cause the unit to enter Suspend mode. In either case, you should save your work and recharge the unit as soon as possible

To lengthen the time between charges, you can perform the following actions:

- **Use external power for PC Card operations whenever possible** – some PC Cards as well as extended communication via the serial port, may require large amounts of power to operate, and can quickly drain the batteries.
Limit the use of backlight – minimize backlight use when you are operating on battery power. You can adjust the backlight timeout level through the Display Settings in the Control Panel or on some units by using the keypad.
- **Shorten Auto-suspend time** – the *BL ident-Handheld* is automatically set to suspend operation to conserve battery power when you have not used the keyboard or the stylus after three minutes. You can increase the Auto-suspend time by changing the Power settings in the Control Panel.

Replacing Batteries/Battery Pack

CAUTION! There is a risk of explosion if you replace the NiMH battery with an incorrect type. Only use the NiMH battery supplied with your unit or a replacement NiMH battery supplied, recommended, or approved by TURCK, Inc.

To replace the rechargeable battery pack or change AA batteries:

1. Turn the power off. With the unit face down, pull the battery cover retaining clip up from its recessed slot and turn the clip in a counter clockwise motion (see Figure 3-6).
2. Lift the cover up and remove the batteries/battery pack.
3. If the unit contains a NiMH battery pack, use the tab to lift up on the battery pack and then out.
4. Close the battery cover and turn the battery cover retaining clip clockwise to lock the cover.

Figure 3-6: Changing Batteries

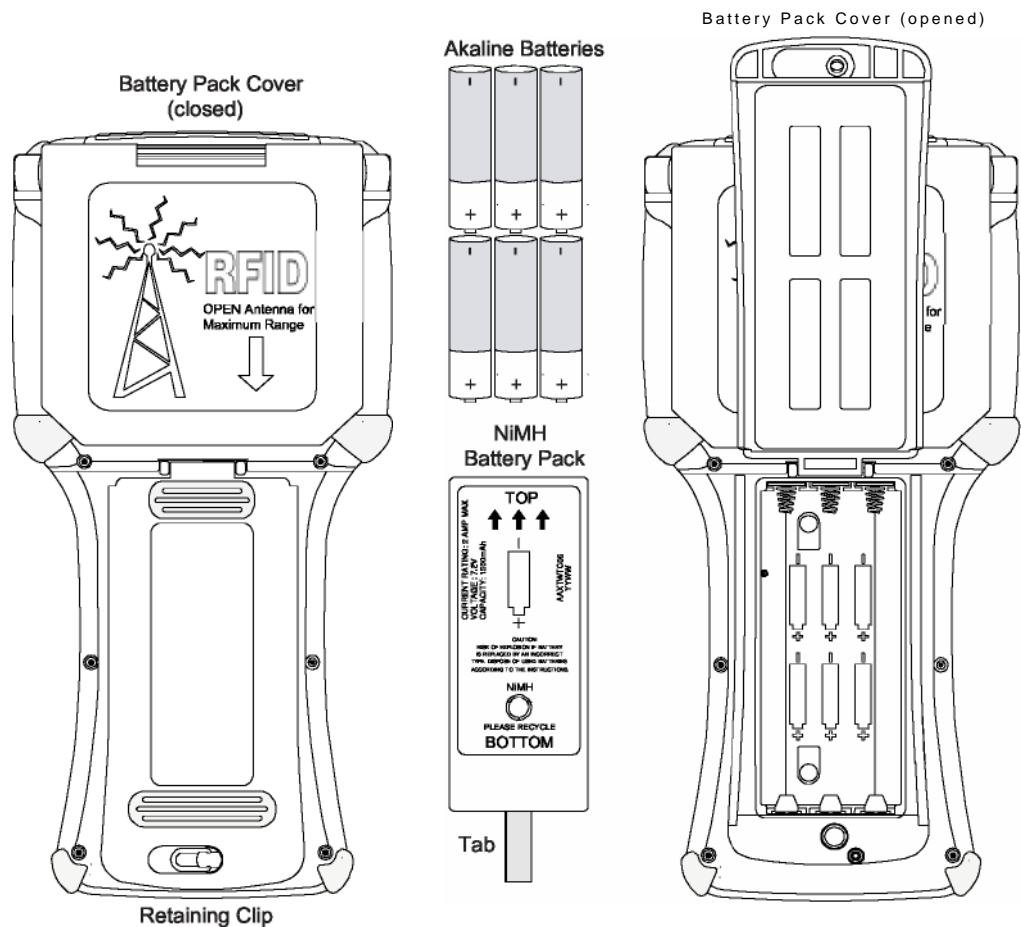

Data Entry

Keypads

45-Key Keypads

In order to provide the functionality of a full-sized keyboard with only 45 keys, the *BL ident*-Handheld keypad must depart from PC-style key assignment conventions by making use of modifier keys. Units configured with the standard 45-key keypad typically utilize five LED indicators (located above the ON/OFF switch) to indicate the active state of keypad modifier keys. Units with 45-key keypads also have keypad functions to adjust the contrast and backlight.

30-Key Keypad

Units with a 30-key keypad provide a full complement of alphabetical characters. Users can access numeric characters, punctuation characters, navigation keys and backlight control via the SHIFT key.

15-Key Keypad

Typically, units shipped with a 15-key keypad have custom keyboard layouts geared toward specific applications that must be loaded onto the unit. To provide you a method of navigating and using Windows CE .NET until you configure and map your keypad in the context of your application using [JETtkbtool](#). TURCK provides a template that shows the default functions (see figure below).

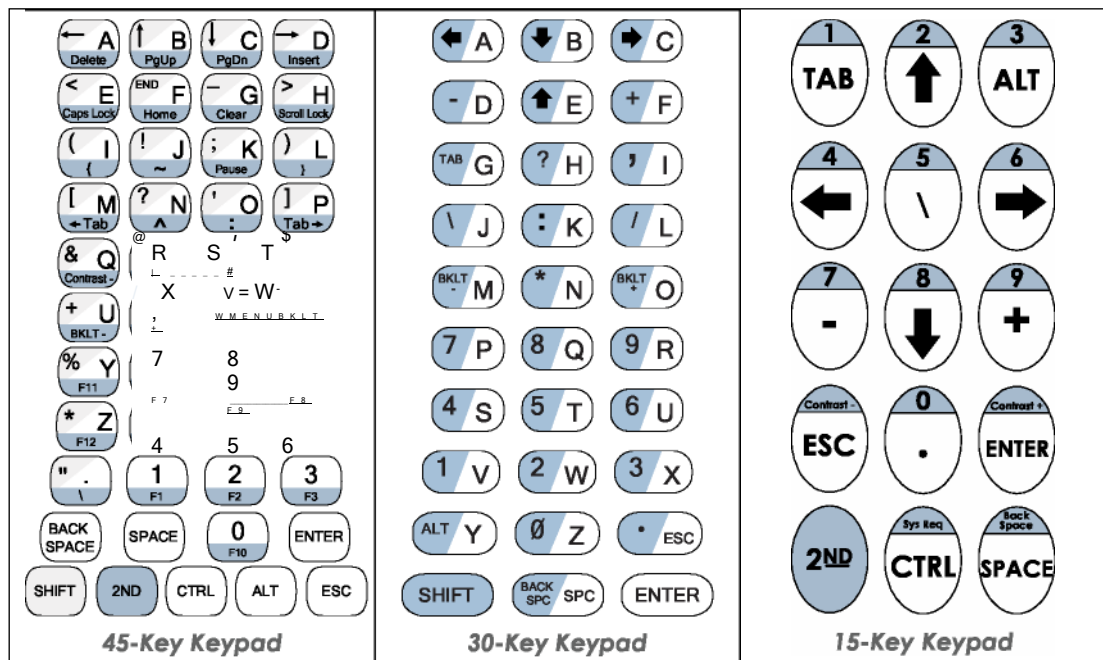

Figure 3-7: Standard Keypad Layouts

Modifier Keys

The following modifier keys (located on the bottom of a standard keypad) enable you to access the various functions that can appear on a key. [Figure 3-8](#) provides an example.

Figure 3-8: 45-Keypad Multifunctional Key



Modifier keys take effect when first pressed and typically remain in effect until you press another key, unless its another Modifier key (see Table 3-2). Optionally equipped units can use LEDs to indicate the selection of a Modifier key.

- **CTRL and ALT Keys** – operate in the same manner as on conventional PCs, except that by default they have a one-time locking action to facilitate one-handed operation.
- **SHIFT Key** – unlike conventional PC keyboards, the SHIFT key enables you to access symbols, punctuation marks and navigation arrows rather than shift alphabetic keys to uppercase.

On standard *BL ident*-Handheld keypads, the functions and characters accessed via the SHIFT key appear in the upper left of a key (shaded in gray in Figure 3-8).

By default, the SHIFT key has a one-time action. However, you can press the Shift key twice and lock the keypad into Shift mode, wear each subsequent key press will only access characters that appear in the upper left of a key. Pressing the Shift key a third time will release Shift mode.

- **2ND Key** – shifts the numeric keys to corresponding function keys (1 = F1, 2 =F2, etc.) that are found on conventional PC keyboards.

It also shifts other keys for punctuation, non-printing characters (such as Delete and TAB), and PC key definitions (such as PageUp, PageDown, Home, Insert and Caps Lock).

On the standard *BL ident*-Handheld 45-key keypad, the functions and characters accessed via the 2nd key appear at the bottom of a key, (shaded in blue in Figure 3-8).

Like the Shift key, the 2ND key has a default one-time action and a locking mode (i.e., pressing the 2ND key twice will lock the keypad into 2ND mode).

.Table 3-2: Modifier Key Actions

<i>Key Presses</i>	<i>Result</i>
A	Lowercase "a"
Shift & A	Move cursor left one position
2ND & A	Delete Character
2ND & Caps Lock	Uppercase "A"

Key Repeat

By default, the *BL ident*-Handheld does not automatically repeat a key stroke when you hold down a key. However, you can enable the key repeat function by configuring the Keyboard setting in the Control Panel.

CE Keyboard

In addition to entering data through the keypad, you can also enter data by using the CE Keyboard. This utility displays a keyboard on the screen to allow data entry via the Command Line or into applications where "text accessibility" control has focus (i.e., text or combo box). To use the CE Keyboard, select **Programs > CeKeys** from the **Start** menu.

To minimize the keyboard, click the keyboard icon that appears in the system tray

Figure 3-9: CE Keyboard

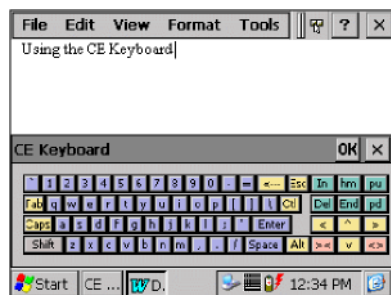

Using the RFID Module

The RFID module can read and write (up to 16k bits) most industry standard 13.56MHz RFID tags and smart labels including for 13.56MHz RFID tag types including ISO-15693, Tag-It by Texas Instruments, I Code by Philips, GemWave by TagSys, and PicoTag from Inside Contactless (see [Table 1-1](#) for specifics).

The RFID module is totally application dependent and derives power from the COM2 port. The RFID module has a flip-out antenna that provides a read range of approximately 3.5 inches (90mm) with a credit card size tag at 90 degrees (see illustration below). For RFID module application integration information, contact TURCK.

Figure 3-10: RFID Read Range

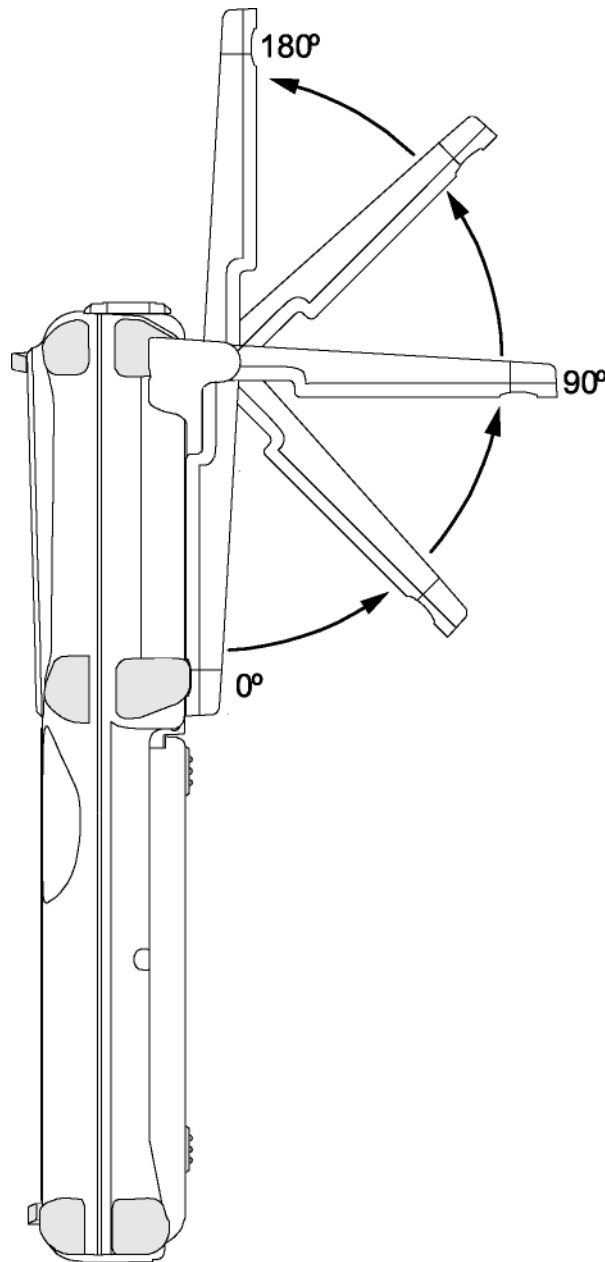

The Windows CE .NET Desktop

This section provides a brief overview of the functions that appear on the *BL ident-Handheld* desktop. For information on how to change desktop settings, refer to Windows CE .NET help (**Start > Help**).



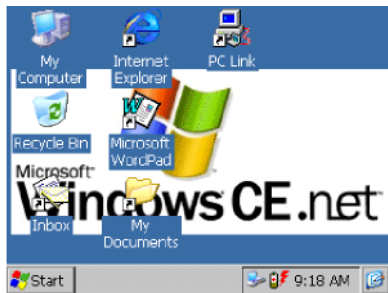



Figure 3-11: Windows CE .NET Desktop



Desktop Functions

You can access the following applications, functions and data entry utilities from the *BL ident-Handheld* desktop:

Table 3-3: Desktop Functions

<i>Icon</i>	<i>Function</i>	<i>Description</i>
	Recycle Bin	Use the Recycle Bin to restore deleted files or empty the bin to create more disk space.
	My Computer	Use My Computer to navigate and view the folders and files stored on the <i>BL ident-Handheld</i> .
	Inbox	Use the Inbox to send and receive e-mail by connecting to a POP3 or IMAP4 server.
	My Documents	The default storage location for documents, graphics, and other files.
	Microsoft WordPad	Use WordPad to create or edit text files that contain formatting or graphics.
	Internet Explorer	Use Pocket Internet Explorer to view Web pages. You will need a modem or Ethernet card to connect to an Internet service provider (ISP) or network.
	PC Link	Use PC Link to make an ActiveSync, Bluetooth or other type of connection to another device

The Taskbar

The taskbar at the bottom of the *BL ident-Handheld* desktop displays the Start button, buttons of currently running applications, the Status Area and the Show Desktop icon.

Tap the Start button to display the Start menu (see below for details). For each open application, a button appears on the taskbar. Simply tap the button to activate the application.

The status area appears on the right and by default displays small icons for the input panel, current time, power status and network connections. Tap an icon to activate the related program.

Tapping the Show Desktop icon minimizes active applications and redisplay the desktop. Tapping the Keyboard icon displays the Input Panel menu for data entry.





Figure 3-12: Windows CE .NET Desktop Taskbar



Power Status Icons

The *BL ident*-Handheld will display power status icons (Table 3-4) in the taskbar status area (Figure 3-12) to indicate power use, charging status and low battery conditions.

Table 3-4: Power Status Icons

<i>Icon</i>	<i>Description</i>
	External AC power supply connected
	Batteries are charging
	Batteries are low – approximately 60 minutes or less of use remaining (the CHARGE/LOW BAT LED will blink red once per second)
	Batteries are very low – approximately 10 minutes or less of use remaining (the CHARGE/LOW BAT LED will turn solid red)

The Start Menu

When you tap **Start**, the Start menu appears.

Figure 3-13: Start Menu

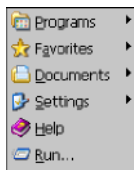

By tapping one of the menu's icons (and not the name), you can:

- Open programs that do not appear on the desktop
- View a list of web sites added to your Favorites List
- View recently accessed documents and images
- Access the Control Panel, establish connections, or configure the Taskbar and Start Menu
- View Help
- Start an application using the Run command
- Place the unit in Suspend mode

SystemCF Folder













The only folder that provides non-volatile (permanent) storage is the SystemCF folder. Information store in other folder will be lost when you remove power from the *BL ident*-Handheld. You can however, have the *BL ident*-Handheld automatically copy files from the SystemCF to other folders when booting up. See [Launching Files at Startup](#) for more information.















Chapter 4: Configuration

The Control Panel

The table below lists the available control panel functions on the *BL ident-Handheld*.

Table 4-1: Control Panel Functions

<i>Icon</i>	<i>Function</i>	<i>Description</i>
	Aux Switch	For units with a second COM that supplies 5VDC output, use this function to set the default power state (On or Off), and test the connected devices.
	Backlight	Use this function to adjust the backlight setting for the following conditions: Line Active, Line Active Inactive, Battery Active and Battery Inactive.
	Battery Select	Select one of the following options to calibrate the power status icons for proper use: NIMH, AC Line or Alkaline.
	Beep Select	Use this function to change the frequency, volume and duration properties of the beep.
	Bluetooth Device Properties	Use this function to scan for other Bluetooth devices and services in the area. For use by Bluetooth cards manufactured by companies other than Socket Communications, Inc. Socket cards use a different control. See Using Bluetooth for more information.
	Certificates	Use this function to import, view or remove certificates, which protect your personal information on the Internet, and protect your computer from unsafe software.
	CPU Speed	For units with 400 MHz processors, use this function to determine the CPU speed (200 or 400 MHz) and mode (Turbo and Non-Turbo) during runtime and cold boot-up. Turbo Mode allows you to clock the processor core at a higher frequency during peak processing requirements.
	Date/Time	Use this function to adjust the date, time and time zone.
	Dialing	Use this function to adjust the dialing location settings and dialing patterns when using a modem.
	Display	Use this function to adjust the backlight timeout, change the background image or change the desktop color scheme.
	Display Rotation	Use this function to rotate the screen 180 degrees (upside down).
	Hot Keys	Use this function to assign functionality to the unit's eight programmable keys (requires Keyboard Mapping).

<i>Icon</i>	<i>Function</i>	<i>Description</i>
	Input Panel	Use this function to adjust the settings for the input panel.
	Internet Options	Use this function to set up connections, security settings and internet related functions.
	Keyboard	Use this function to change the repeat delay and repeat rate.
	Network and Dial-up Connections	Use this function to change network adapter settings and/or set up identification for remote networks.
	Owner	Use this function to enter the owner name, address, phone numbers and network ID.
	Password	Use this function to enable password protection and set a password.
	PC Connection	Use this function to enable direct connection to a desktop computer
	Power	Use this function to: <ul style="list-style-type: none"> ~ Check battery power ~ Set device to turn off when idle ~ Set up power schemes ~ Check the power levels of your system devices
	Regional Settings	Use this function to change the appearance of region specific information, such as date, time and currency.
	Remove Programs	This function enables you to remove programs installed in RAM.
	Storage Manager	This function enables you to perform the following tasks: <ul style="list-style-type: none"> • View partition information • Format a partition • Create or delete a partition • Mount or dismount a partition • Scan and repair a partition. • Defragment a partition
	Stylus	Use this function to recalibrate the touch screen and adjust the stylus double-tap rate.
	System	Use this function to view system information, change the RAM (Program/Storage memory) division, change the device name and change the device description..
	VComAdj	Use this function to minimize screen flicker and adjust contrast.

Changing System Settings

Any time you make changes through the Control Panel (such changing the time zone), you must also update the persistent registry to store the changes in internal compact flash memory to make the changes permanent.

For example, to change the time zone and save the changes to the registry:

1. Select Start > Settings > Control Panel.

Note: Tap the icon, not the name.

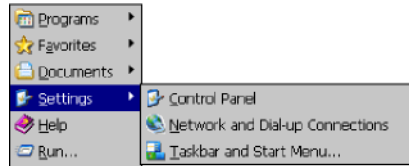

2. On the Control Panel, double-tap **Date/Time**. The Date/ Time Properties dialog box appears. You can now set the date, time and time zone.

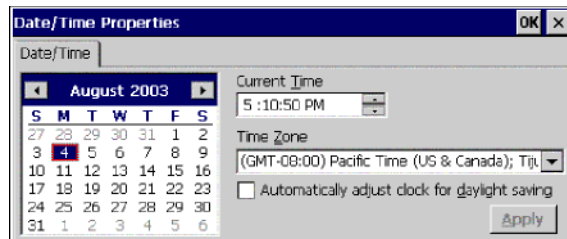

3. To adjust the **Current Time**, use the scroll bars to increase or decrease the value, or tap hours, minutes, seconds or AM/PM indicator to set the values individually.
4. To select the **Time Zone**, use the corresponding list.
5. To adjust the **Date**, either:
 - Tap the arrows on the calendar to select the previous/next month
 - Double-tap the month or year to select it from a list
 - Tap a day to select it
6. To adjust the clock automatically for daylight savings, check the corresponding box.
7. Tap **Apply** to have your setting take effect.
8. Tap **OK** to close the Date/Time Properties dialog box and return to the Control Panel.
9. Tap **OK** to exit the Control Panel.
10. From the **Start** menu, select **Programs** and tap **Save Registry**.

Taskbar and Start Menu Settings

To change the Taskbar and Start Menu settings:

1. Select **Start > Settings> Taskbar & Start Menu**. The Taskbar and Start Menu Properties dialog box opens:
2. Select the **General** tab:

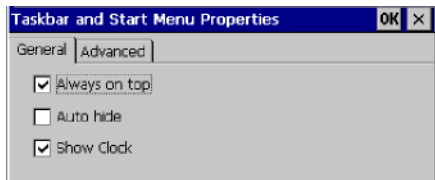

3. Check **Always on Top** to ensure that the taskbar is always visible, even when a program appears in a full window (maximized).
4. Check **Auto hide** to display the taskbar just when you point to the taskbar area.
5. Check **Show Clock** to display the time of day in the taskbar.
6. Select the **Advanced** tab:

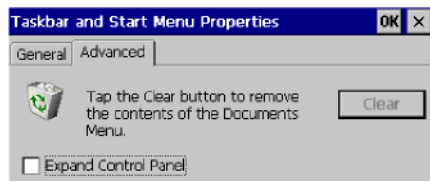

7. Tap the **Clear** button to remove the contents of the documents menu.
8. Check the **Expand Control Panel** box to display the contents of the Control Panel as items on the Settings | Control Panel menu.
9. Tap **OK** to save the settings and exit the menu.
10. From the **Start** menu, select **Programs** and tap **Save Registry**.

Using the Compact Flash Slot

BL ident-Handheld's equipped with a standard Compact Flash Slot access cover will allow you to access the slot to insert and remove Compact Flash and device cards.

If you intend to use a device card, it may also be necessary to install a driver. If so, make sure the card is Windows CE .net compatible and you have the necessary drivers. If you are not sure, check with the card manufacturer before attempting to install the card.

To transfer files using the compact flash slot:

1. With the front of the display facing you, push the compact flash slot cover (located on top of the unit) to the left.

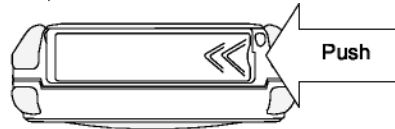

2. The slot cover will automatically pop open.

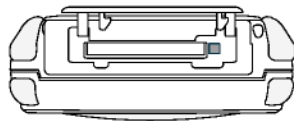

3. Insert the compact flash/ device card into the slot with the front of the display facing you and the top of the card pointed to the slot until it clicks and the release lever moves upward.

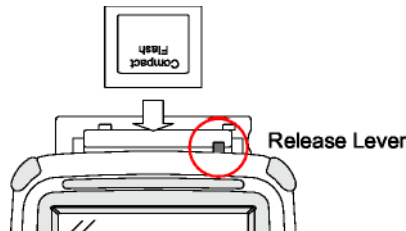

4. Close the cover.
5. When inserting memory cards, a "UserCF" folder will appear when you open **My Computer**. You can then copy and paste the contents of UserCF to the other folders on the *BL ident-Handheld*.

When inserting device cards, the *BL ident-Handheld* will attempt to recognize the device. If it finds a driver for the device, the *BL ident-Handheld* will display a dialog box for that device. For example:

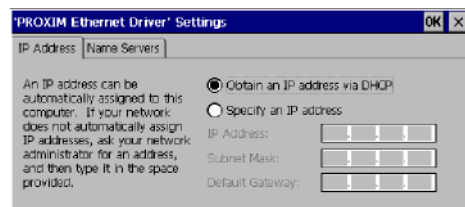

If the *BL ident-Handheld* cannot find a driver for the device, it will display the following dialog box:

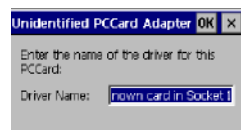

6. If the correct card type appears, you can enter the appropriate information in the dialog box as required and then tap **OK** to complete the installation.
7. To remove a card from a slot, simply push the card release lever down and remove the card.

Network Connections

You can connect directly to a network using one of the following card types to access e-mail, access files available on the network server, and browse the Internet:

- Wired Ethernet CF Card
- WLAN 802.11b (Integrated or CF Card)
- Bluetooth Class 1 (Integrated or CF Card)
- Bluetooth Class 2 CF (Integrated or Card)

Creating a Wired Ethernet Network Connection

To create a Wired Ethernet connection:

1. Insert the Ethernet card into the BL ident-Handheld and connect the cable to the network.
2. Select **Start > Settings > Control Panel**. Double-tap **Network and Dial-Up Connections**.
3. Double-tap the connection icon for the adapter. For example, if you have a NE2001 Ethernet adapter, double-click the **NE2001** connection icon.
4. In the Ethernet Driver Settings dialog box, select **Obtain an IP address via DHCP** and tap **OK**.

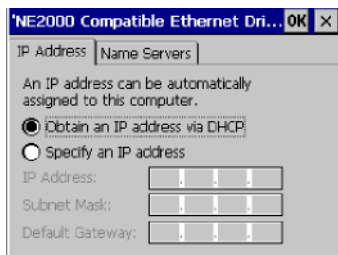

5. If prompted, enter the **User Name**, **Password**, and **Domain** name you use to log on to your network.
6. From the **Start** menu, select **Programs** and tap **Save Registry**.

Creating Network Connection using a WLAN 802.11 b Card

To create a network connection using a WLAN 802.11b card:

1. Insert the WLAN 802.11b card into the BL ident-Handheld.
2. Select **Start > Settings > Control Panel**. Double-tap **Network and Dial-Up Connections**.
3. Double-tap the connection icon for the adapter. For example, if you have a NE2001 Ethernet adapter, double-click the **NE2001** connection icon.
4. In the Ethernet Driver Settings dialog box, select **Obtain an IP address via DHCP** and tap **OK**.
5. If prompted, enter the **User Name**, **Password**, and **Domain** name you use to log on to your network.
6. From the **Start** menu, select **Programs** and tap **Save Registry**.

Setting Up Identification for Remote Networks

To set up identification for remote networks:

1. Select Start > Settings > Control Panel.
2. Double-tap **Owner**.
3. In the **Network ID** tab, enter the user name, password, and domain name you use to log on to the remote network.
4. From the **Start** menu, select **Programs** and tap **Save Registry**.

Connecting to a Mail Server

You can send and receive e-mail by connecting to a POP3 or IMAP4 server. Inbox contains an e-mail service for each method you use. For either service, you must establish a connection to your Internet service provider (ISP) or to the appropriate mail server in your local area network. In addition to creating this connection, you must also create the e-mail service.

Prior to setting up a service, you should obtain the following information from your ISP or network administrator: POP3 or IMAP4 server name, SMTP host name, user name, password and domain name (for network connections only).

Notes: Windows CE .Net does not support other mail protocols such as AOL or services that use special authentication, such as MSN. However, you can gain access to the Internet through these services. If you use the same service to connect to different mailboxes, set up and name a different service for each connection. For additional information about the inbox, refer to Windows CE .NET online help.

To connect to your POP3 or IMAP4 mail server:

1. Select Start > Programs > Inbox > Services > Options. The Options dialog box opens.

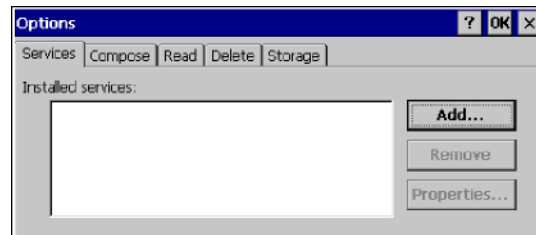

2. Select the **Services** tab and tap **Add**. The Service Name dialog box opens.

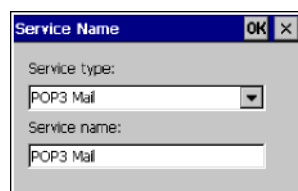

3. From the **Service type** list, select **POP3 Mail** or **IMAP4 Mail**.
4. Enter a unique name for the service (you cannot change this name once entered).
5. Tap **OK**. The Mail Service Setup wizard appears.

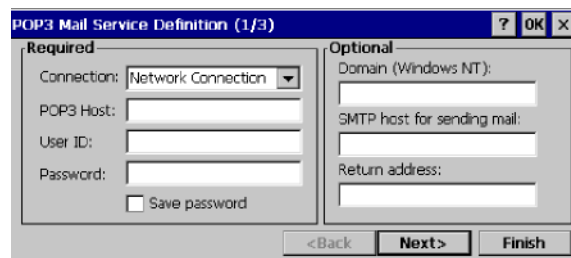

6. In the Required panel:

Select the name of the connection you created to connect to the mail server. If you are receiving e-mail through a network (Ethernet) connection, select **Network Connection**.

If you want Inbox to use your current connection, select **(none)**.

If you have not created a connection, select **Create new connection**, double-tap the Make New Connection icon, and follow the instructions in the wizard. When finished, select Inbox in the Taskbar and continue setting up Inbox.

Enter the **POP3 Host** or Server (IMAP4) name of the mail server you use to receive and send messages.

Enter the **User ID** (user name or mailbox ID) assigned to you.

Enter the password you will use to access this mail account. If you do not want a prompt to enter the password each time you connect, select **Save password**.

7. In the Optional panel:

If connecting to a network that uses Windows NT domain security, enter the Windows NT domain name.

If your mail service uses a separate server for SMTP, enter the **SMTP Host** name. For POP3 Mail service with an ISP, the ISP must use an SMTP mail gateway.

Enter your return e-mail address.

8. Tap **Next**. The General Preferences dialog box opens.

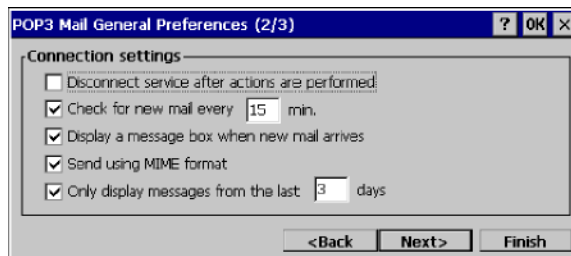

9. Choose any of the settings, all of which are optional, then click **Next**. The Inbox Preferences dialog box opens.

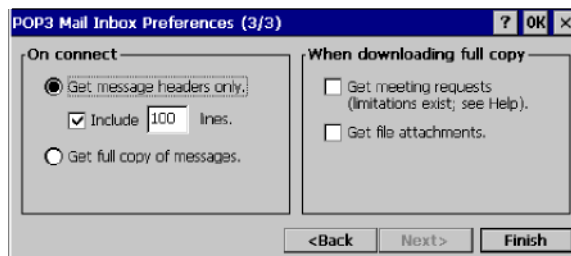

10. Choose any of the settings as needed, then click **Finish**. The Mail Service Setup wizard closes and the Options dialog box reappears.

Note: Receiving entire messages consumes storage memory.

11. Close the Options dialog box to return to the Inbox.

12. From the **Start** menu, select **Programs** and tap **Save Registry**.

ActiveSync

ActiveSync is a desktop utility program (available as a free download from Microsoft) that allows you to synchronize certain types of information between a PC and the BL *ident*-Handheld. You can also use ActiveSync to transfer files and install programs on the BL *ident*-Handheld.

When connecting the BL *ident*-Handheld to the PC via ActiveSync, you can opt to create a partnership and subsequently have the PC automatically recognize the BL *ident*-Handheld and synchronize information. You can also create a temporary Guest partnership to copy files and install programs.

The following procedures describe how to make an ActiveSync connection using a serial interface cable. For information on how to make an ActiveSync connection using Bluetooth or Wi-Fi, refer to the appropriate manual.

Initial Communication

To setup initial communication between the PC and the BL *ident*-Handheld:

1. Connect an interface cable to an available COM port on the PC and the BL *ident*-Handheld's RS-232 port.
2. On the PC, start ActiveSync.



3. On the ActiveSync menu bar, select **Connection Settings** from the **File** menu. The Connection Settings dialog box opens.



4. If not selected, check the **Allow serial cable or infrared connection to this COM port** box, and assign the number of the available COM port (typically COM1).
5. Click **OK** to exit.

6. On the ActiveSync menu bar, select **Get Connected** from the **File** menu. ActiveSync will then start the Get Connected wizard.



7. Click **Next**. ActiveSync will start attempting to establish a connection (this process will take several seconds).

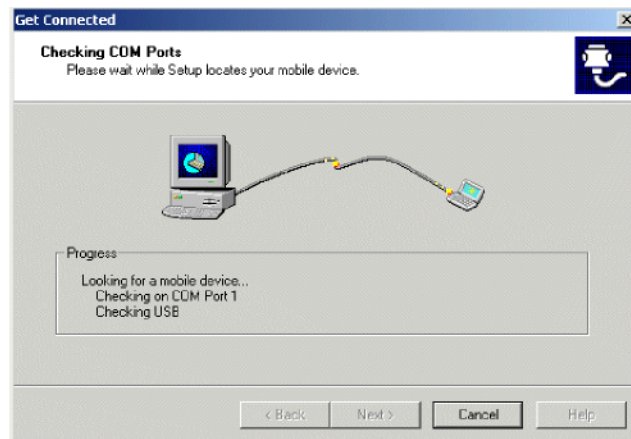

8. On the *BL ident*-Handheld, tap PC Link



The following message box appears:

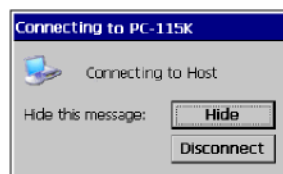

9. If ActiveSync successfully establishes communications, the ActiveSync dialog will briefly reappear on the PC and start the New Partnership dialog wizard.



10. Select your Partnership option as needed and complete the wizard. The ActiveSync dialog box will reappear and display a status of "Connected." For example:



11. On the *BL ident*-Handheld, an icon indicating a ActiveSync connection will appear in the system tray.



12. To terminate the ActiveSync connection, double-tap the connection icon to display the Connect To dialog box and tap **Disconnect**.

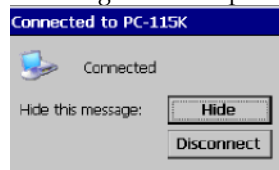

Subsequent Communication

After you install ActiveSync and establish the initial communication between the PC and the *BL ident-Handheld*, use the following procedure to set up subsequent sessions:

1. If not already attached, connect an interface cable to an available COM port on the PC and the RS-232 port on the *BL ident-Handheld*.
2. On the *BL ident-Handheld* desktop, tap **PC Link** to attempt to reestablish communications
3. When communications is successfully reestablished, the New Partnership wizard appears.



4. Select **No** on the PC and then click **Next**. A status of “Connected” should appear in the ActiveSync window.



Persistent Registry

Saving Changes to the Registry

The *BL ident-Handheld* internal memory consists of DRAM and Flash. Typically, any changes made to the *BL ident-Handheld* including file creation are temporarily stored in the unit's DRAM. You must then copy the files from DRAM to internal flash memory or a removable compact flash card to store the information permanently.

Consequently, if you do not store the information to flash memory and the unit loses power, all information stored in DRAM will be lost. However, whenever you make changes that affect the registry, such as changing settings in the Control Panel or installing software, you can permanently store registry changes without writing to flash memory by using the Persistent Registry.

Note: The *BL ident-Handheld* will store registry information every time you perform a suspend operation.

To store registry information on the *BL ident*-Handheld permanently:

1. From the **Start** menu, select **Programs** and tap **SaveReg**.

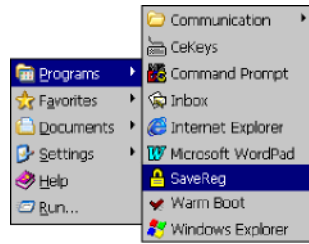

2. The *BL ident*-Handheld will begin saving the registry.

Saving Registry, Standby..

After you successfully save the registry, a message box will appear:

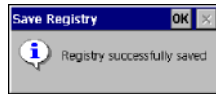

3. Tap **OK** to close the message box.

Resetting the Registry

To reset the Windows CE .NET registry back to the factory default settings:

1. Turn off the *BL ident*-Handheld.
2. While holding the key in Column 1, Row 1 (upper leftmost) and the key in Column 1, Row 3, turn on the *BL ident*-Handheld. For example:

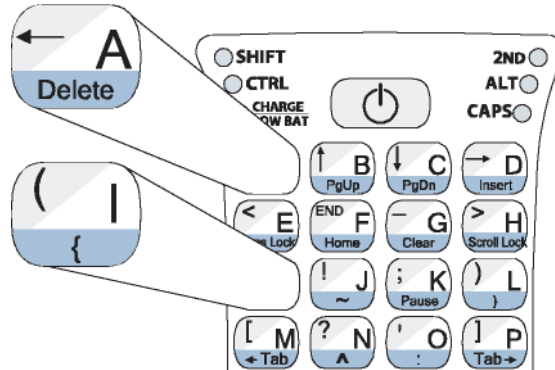

3. If you are successful, the screen will display version information, followed by “Invalidating Persistent Registry,” before it completes the boot up process.

Chapter 5: Troubleshooting

<i>Problem</i>	My BL <i>ident</i> -Handheld does not respond when I press the power button.
<i>Solution</i>	Is the unit in Suspend mode? If battery-powered, check the batteries. Are all cables connected properly: <ul style="list-style-type: none">• Is the power supply plugged into an active AC outlet?• Is the power connector securely plugged into the BL <i>ident</i>-Handheld

<i>Problem</i>	I changed my system settings, but when I turn on the BL <i>ident</i> -Handheld my settings are gone.
<i>Solution</i>	You must save the registry after making any system or configuration changes.

<i>Problem</i>	I transferred files to the BL <i>ident</i> -Handheld from my host computer, but when I turn on the BL <i>ident</i> -Handheld my transferred files are missing.
<i>Solution</i>	To store transferred files permanently, you must file copy the files into internal flash memory or a compact flash card. Occasionally, transferred files can be hidden from view, double-tap My Computer, select Options from the View menu and clear all boxes.

<i>Problem</i>	I cannot connect to the development system using ActiveSync.
<i>Solutions</i>	Did you install ActiveSync using the Administrator account? Check the cable connections. Check the serial communications configuration. Make sure the correct COM port is available. In ActiveSync, check the Connection Settings for the connection type you are using (USB, Serial or Ethernet).

<i>Problem</i>	The screen is too light or too dark.
<i>Solution</i>	Adjust the brightness via the brightness control in the Control Panel.

Problem	The stylus is not responding properly.
Solution	The screen is not calibrated correctly to interpret the screen taps. You need to recalibrate the screen.
Problem	The <i>BL ident</i> -Handheld acts slowly.
Solutions	The unit may be short of program memory or storage memory. Increase the amount of storage or program memory through the System control in the Control Panel. You can also delete any unnecessary files.
Problem	I get little or no sound from the <i>BL ident</i> -Handheld.
Solution	Adjust the volume and sound properties via the Volume and Sound control in the Control Panel.
Problem	The <i>BL ident</i> -Handheld does not recognize a compact flash or device card.
Solution	The card is not installed or seated properly. Reinstall the card. There may be an unstable connection between the card and the <i>BL ident</i> -Handheld. Remove the card, clean the edge connector with a soft dry cloth, and reinstall the card.
Problem	The <i>BL ident</i> -Handheld goes into auto-suspend after a short period of inactivity.
Solution	As a default, the device will auto-suspend after two minutes of inactivity while running on batteries and after thirty minutes of inactivity when running on AC power. Adjust the power management properties via the Power control in the Control Panel.
Problem	No sound is heard when you tap the touch screen or press a key.
Solution	Volume setting is low or turned off. Check the volume slider in the Volume & Sound properties dialog box in the Control Panel.

Appendix A: Specifications

<p>Power</p> <p>Recharge Voltage: 11 to 18 VDC, 1.5A (North America Only) Battery Type: Nickel Metal Hydride Rechargeable (or 6 AA alkaline batteries)</p> <ul style="list-style-type: none">~ Current Rating: 2 Amp Maximum~ Voltage: 7.2 Volts~ Capacity: 1400 mAh
<p>Display</p> <p>Supertwist Nematic Liquid Crystal TFT with white LED backlight Resolution: 320 x 240 pixels QVGA color Touch Screen</p>
<p>Environmental</p> <p>Operating Temperature: 0°C to +50°C Storage Temperature: -25°C to +70°C Charging Temperature: 0°C to + 40°C Humidity: 5-95% Non-condensing</p>
<p>CPU</p> <p>Type: Intel PXA255 processor with XScale technology Instruction Set Architecture: ARM v.5TE Speed: 200 MHz (400 MHz optional) Operating System: Windows CE .NET 4.2 Professional</p>
<p>Memory and Mass Storage</p> <p>SDRAM: 64MB Internal Compact Flash: 64 MB standard (16MB reserved for OS), upgradeable to 128MB Optional: Compact flash card slot</p>
<p>RFID Module</p> <p>Multi-protocol read/write support for 13.56MHz RFID tag types including ISO-15693, Tag-It by Texas Instruments, I Code by Philips, GemWave by TagSys, and PicoTag from Inside Contactless (see Table 1-1 for specifics). Read Range: 3.152-3.546 inches (80-90 mm) Output Power Measurement: 22.8 dbm = 200 mW</p>
<p>User Input</p> <p>Touch Screen Key Pad: 45-Key membrane (9 rows x 5 columns) or 15-key elastomeric (5 x 3) Feedback: Tactile and audible Optional: LED backlighting</p>

Indicators

5 Modifier Key/Programmable LEDs

Charge/Low Battery Indicator (battery-powered units only)

Interface Capability

One available serial port configured for RS-232 that can also provide input power (11-18VDC) and recharging capability.

Optional interface connectors (available at time of factory configuration) include the *BL ident* connect system, DE-9 male or female connectors and a six-pin modular connector.

Interface connections (available at time of factory configuration) can optionally provide output at 5 VDC to operate peripheral devices.

Physical Dimensions

Height (H): 9.84 Inches (250 mm)

Width (W): 4.75 Inches (120.7 mm)

Depth (D): 2.37 Inches (60.2 mm)

Weight :

- Without Batteries: 27 Ounces (765.4 grams)
- With Alkaline Batteries: 32 Ounces (907.2 grams)
- With NiMH Batteries: 33 Ounces (935.5 grams)

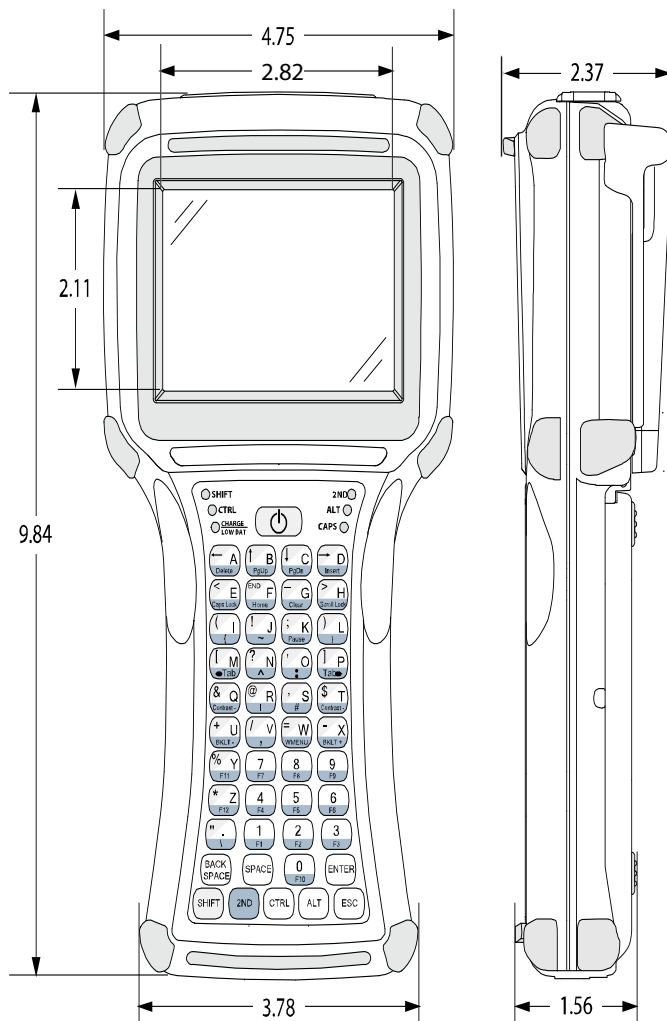

Specifications subject to change

Appendix B: Signal and Pin Assignments

BL ident Connect Cables

Figures B-1 and B-2 list the standard RS-232 signal and pin assignments for the BL ident connect cables. Figure 6-2: 91708 Cable (Male DE9) RS-232 Signal and Pin Assignments

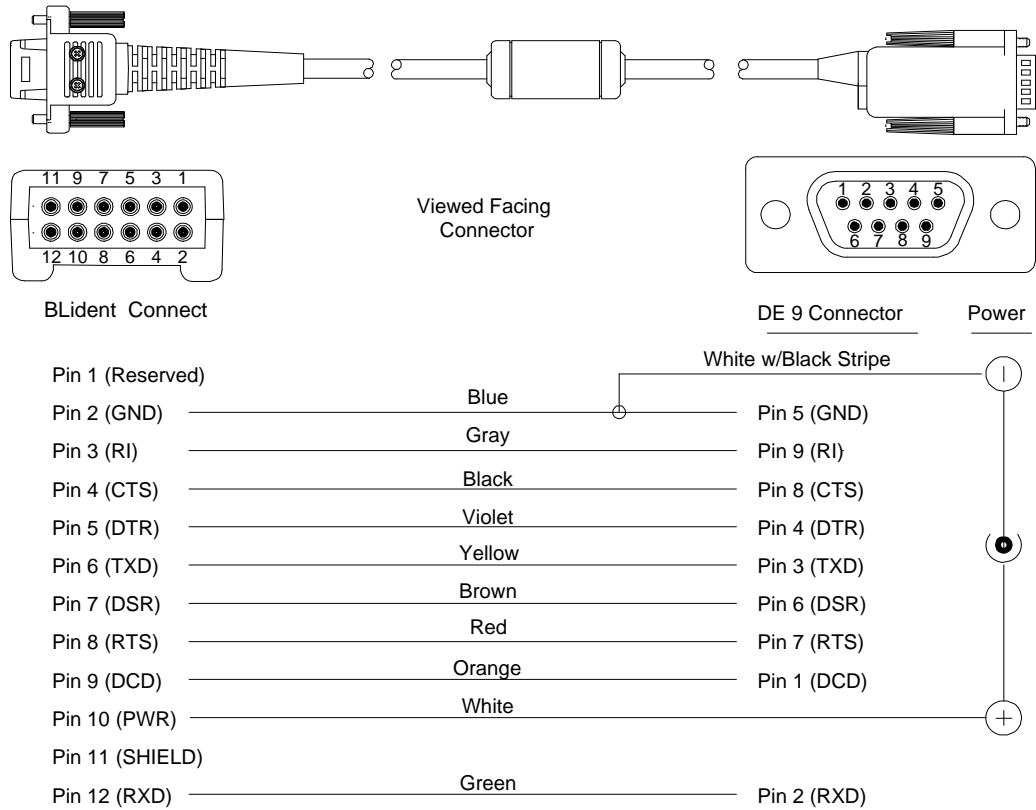
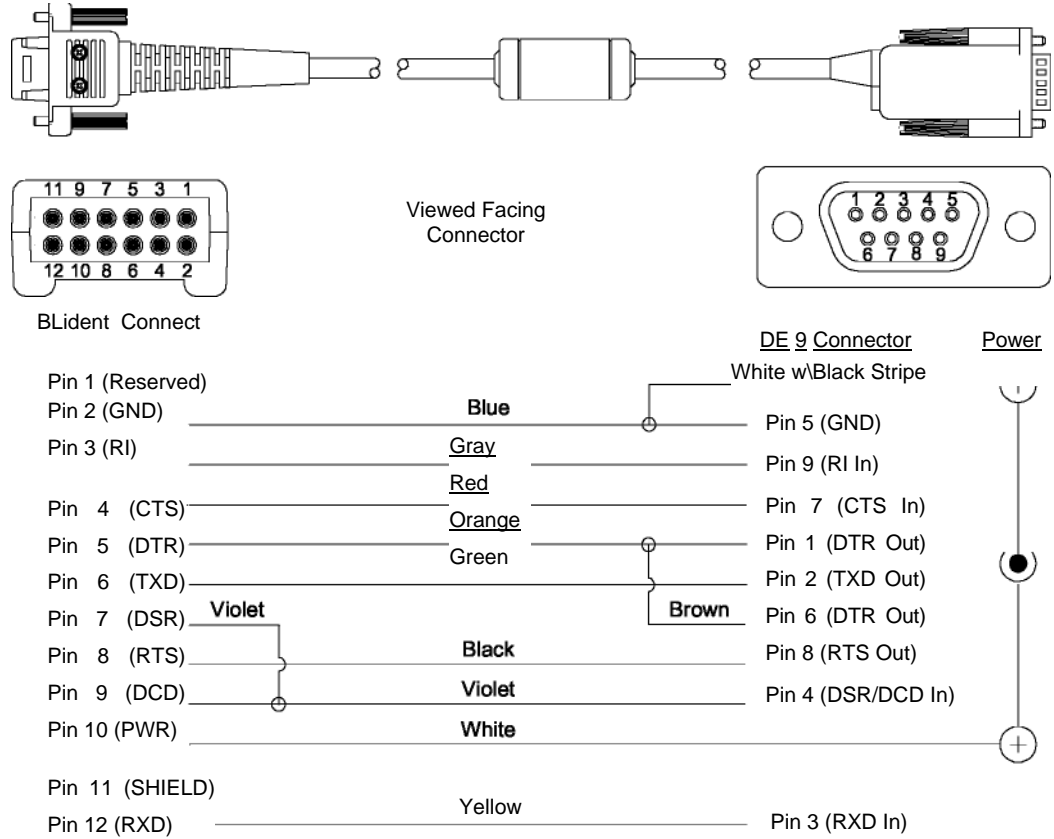

Figure 6-3: 91709 Cable (Female DE9) RS-232 Signal and Pin Assignments



1210 Series Modular Interface Cables

Figure B-3 lists the signal and pin assignments for 1210 series modular cables.

Figure 6-4: 1210 Series Modular Cable Signal and Pin Assignments

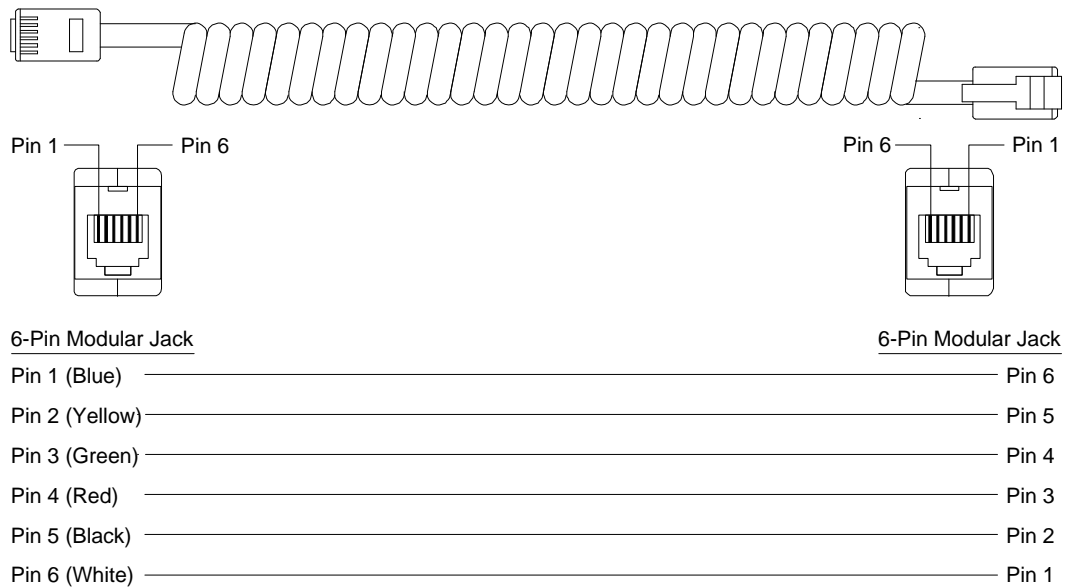

Modular Cable Adapters

Pin descriptions assume connection through reversing cables (1210-7, 1210-15) to *BL ident-Handheld*.

CELAT-P Adapter

Figure B-4 lists the signal and pin assignments for the CELAT-P adapter.

Figure 6-5: CELAT-P Adapter

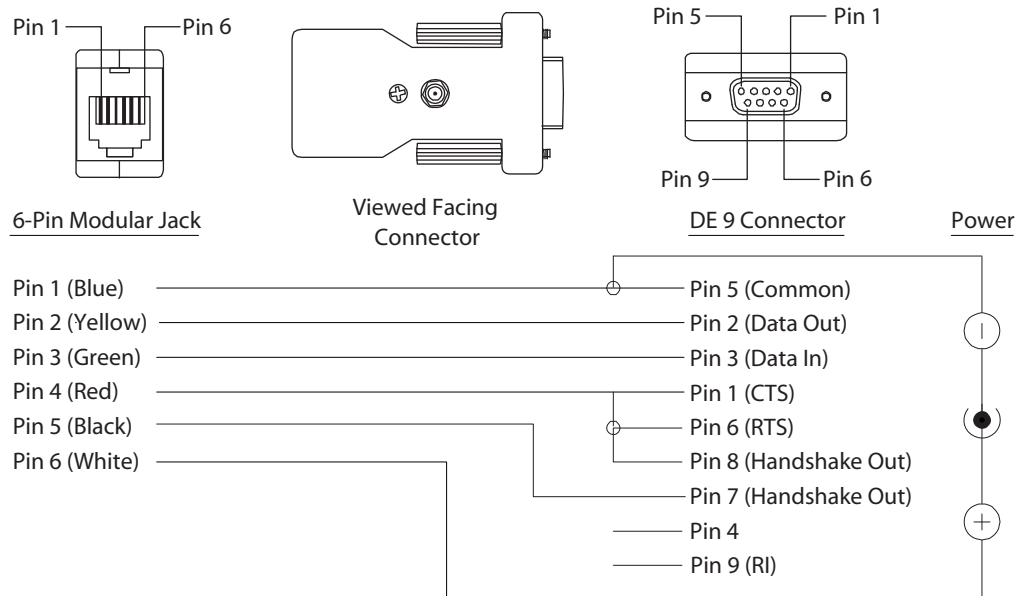

Null Modem Cable

Figure B-5 lists the signal and pin assignments for TURCK' 14375 DE-9 Female to DE-9 Female null modem cable. Please note that this cable differs from standard null modem cables in that it use Pin 9 for input power for the *BL ident-Handheld*.

Figure 6-6: DE-9 Female to DE-9 Female Null Modem Cable

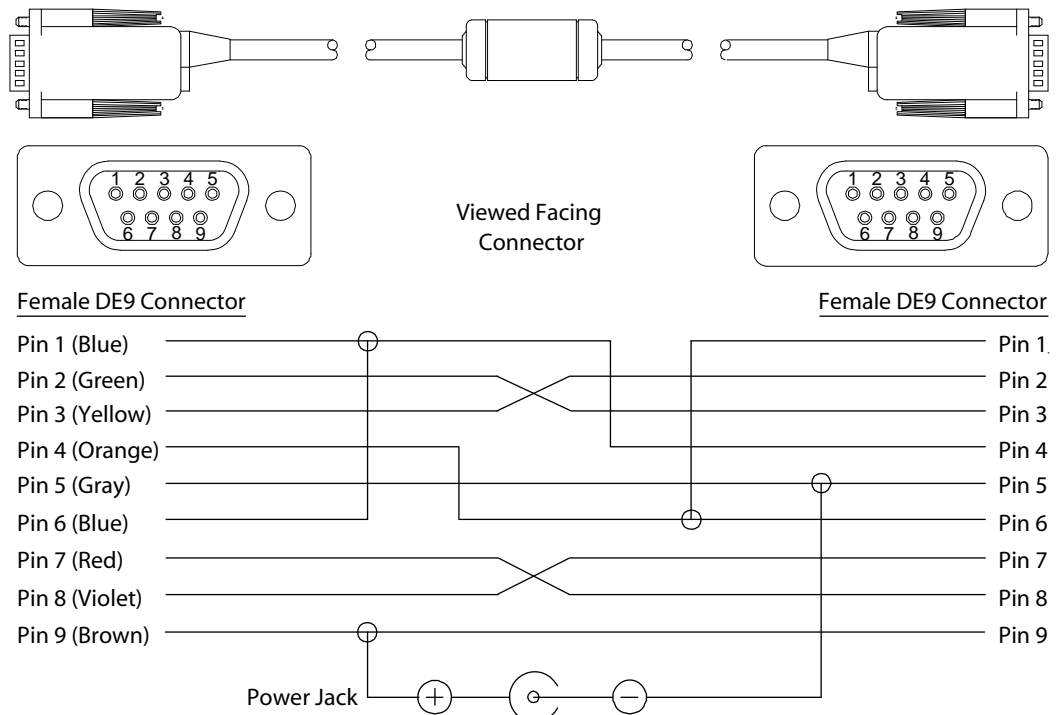

Appendix C: Keyboard Mapping Files

Keyboard Mapping Files Notes

The following table lists the allowable values and the names of allowable values that you can map to a keypad.

Table 6-1: Allowed Values in Key Map Files

A	V	CARET	F9	NUMPAD1	SEMICOLON
B	W	CLEAR	F10	NUMPAD2	SHIFT
C	X	COLON	F11	NUMPAD3	SLASH
D	Y	COMMA	F12	NUMPAD4	SPACE
E	Z	CONTROL	FUNCTION	NUMPAD5	STAR
F	(DELETE	HASH	NUMPAD6	SUBTRACT
G)	DOLLAR	HOME	NUMPAD7	TAB
H	[DOUBLEQUOTE	INSERT	NUMPAD8	TILDA
I]	DOWN	LEFT	NUMPAD9	UNDERLINE
J	{	END	KEY0	PAGEDOWN	UP
K	}	EQUAL	KEY1	PAGEUP	USER_DEF1
L	<	ESCAPE	KEY2	PAUSE	USER_DEF2
M	>	EXCLAMATION	KEY3	PERCENT	USER_DEF3
N	ADD	F1	KEY4	PERIOD	USER_DEF4
O	ALT	F2	KEY5	PIPE	USER_DEF5
P	AMPERSAND	F3	KEY6	PRINT	USER_DEF6
Q	AT	F4	KEY7	QUESTION	USER_DEF7
R	BACKQUOTE	F5	KEY8	QUOTE	USER_DEF8
S	BACKSLASH	F6	KEY9	RETURN	USER_DEF9
T	BACKSPACE	F7	NUMLOCK	RIGHT	USER_DEF10
U	CAPSLOCK	F8	NUMPAD0	SCROLL	WINMENU

Scan codes "USER_DEF1" through "USER_DEF10" can produce some proprietary action, such as backlight adjustment, display rotation, etc. For each user-defined key-function (except as noted below), you must supply the appropriate code in the keyboard driver to produce the desired effect. "USER_DEF3" defines the Backlight+ key and "USER_DEF4" defines the Backlight- key.

The "FUNCTION" keyword identifies those function accessed through the "2nd" key. The "RETURN" keyword identifies the "ENTER" key. The "WINMENU" keyword produces the Windows "Start" menu.

The number in COLS must always be set to five regardless of the actual number of columns (applies to 15-key keypads as well).

Do not change the ID number, it must match the number stored in the *BL ident*-Handheld's hardware configuration block.

45-Key Key Map

```
# 55 Key JettCE keyboard for P/N 11406 Rev A. keypad
# The keyword "FUNCTION" is used for the "2nd" key.
# The keyword "RETURN" is used for the "ENTER" key.
# "USER_DEF1" defines the Contrast+ key
# "USER_DEF2" defines the Contrast- key
# "USER_DEF3" defines the Backlight-INCREASE key
# "USER_DEF4" defines the Backlight-DECREASE key
# "WINMENU" produces the Windows "Start" menu.

# The line and the end of the line
ROWS 11
COLS 5

# The id of the keyboard.
ID 55

# The basic scan codes.
#      Row,Col,Scan Code
SCANCODE 0, 0-> A          SCANCODE 0, 1 -> B          SCANCODE 0, 2 -> C
SCANCODE 0, 3-> D          SCANCODE 1, 0 -> E          SCANCODE 1, 1 -> F
SCANCODE 1, 2-> G          SCANCODE 1, 3 -> H          SCANCODE 2, 0 -> I
SCANCODE 2, 1-> J          SCANCODE 2, 2 -> K          SCANCODE 2, 3 -> L
SCANCODE 3, 0-> M          SCANCODE 3, 1 -> N          SCANCODE 3, 2 -> O
SCANCODE 3, 3-> P          SCANCODE 4, 0 -> Q          SCANCODE 4, 1 -> R
SCANCODE 4, 2-> S          SCANCODE 4, 3 -> T          SCANCODE 5, 0 -> U
SCANCODE 5, 1-> V          SCANCODE 5, 2 -> W          SCANCODE 5, 3 -> X
SCANCODE 6, 0-> Y          SCANCODE 6, 1 -> KEY7       SCANCODE 6, 2 -> KEY8
SCANCODE 6, 3-> KEY9       SCANCODE 7, 0 -> Z          SCANCODE 7, 1 -> KEY4
SCANCODE 7, 2-> KEY5       SCANCODE 7, 3 -> KEY6       SCANCODE 8, 0 -> PERIOD
SCANCODE 8, 1-> KEY1       SCANCODE 8, 2 -> KEY2       SCANCODE 8, 3 -> KEY3
SCANCODE 9, 0-> BACKSPACE  SCANCODE 9, 1 -> SPACE      SCANCODE 9, 2 -> KEY0
SCANCODE 9, 3-> RETURN     SCANCODE 10, 0 -> SHIFT     SCANCODE 10, 1 ->
FUNCTION
SCANCODE 10, 2 -> CONTROL  SCANCODE 10, 3 -> ALT      SCANCODE 10, 4 -> ESCAPE

# Table 0 is always the unshifted values.
TABLE 0, basic, UNSHIFTED
TABLE 1, func, FUNCTION
TABLE 2, shift, SHIFT

# Func remapping table.
REMAPPING func, A -> DELETE          REMAPPING func, B -> PAGEUP
REMAPPING func, C -> PAGEDOWN       REMAPPING func, D -> INSERT
REMAPPING func, E -> CAPSLOCK       REMAPPING func, F -> HOME
REMAPPING func, G -> CLEAR          REMAPPING func, H -> SCROLL
REMAPPING func, I -> {              REMAPPING func, J -> TILDA
REMAPPING func, K -> PAUSE          REMAPPING func, L -> }
REMAPPING func, M -> BACKTAB        REMAPPING func, N -> CARET
REMAPPING func, O -> COLON          REMAPPING func, P -> TAB
REMAPPING func, Q -> USER_DEF2     REMAPPING func, R -> PIPE
REMAPPING func, S -> HASH           REMAPPING func, T -> USER_DEF1
REMAPPING func, U -> USER_DEF4     REMAPPING func, V -> COMMA
REMAPPING func, W -> WINMENU        REMAPPING func, X -> USER_DEF3
REMAPPING func, Y -> F11            REMAPPING func, Z -> F12
REMAPPING func, PERIOD -> BACKSLASH REMAPPING func, KEY7 -> F7
REMAPPING func, KEY8 -> F8 REMAPPING func, KEY9 -> F9
func, KEY4 -> F4 REMAPPING func, KEY6 -> F5
-> F6                                REMAPPING func, KEY1 -> F1
```

REMAPPING func, KEY2 -> F2
REMAPPING func, KEY0 -> F10

REMAPPING func, KEY3 -> F3

Shift remapping table.
REMAPPING shift, A -> LEFT
REMAPPING shift, C -> DOWN
REMAPPING shift, E -> <
REMAPPING shift, G -> UNDERLINE
REMAPPING shift, I -> (
REMAPPING shift, K -> SEMICOLON
REMAPPING shift, M -> [
REMAPPING shift, O -> BACKQUOTE
REMAPPING shift, Q -> AMPERSAND
REMAPPING shift, S -> QUOTE
REMAPPING shift, U -> SUBTRACT
REMAPPING shift, W -> EQUAL
REMAPPING shift, Y -> PERCENT
REMAPPING shift, PERIOD -> DOUBLEQUOTE
#REMAPPING shift, KEY8 ->
#REMAPPING shift, KEY4 ->
#REMAPPING shift, KEY6 ->
#REMAPPING shift, KEY2 ->
#REMAPPING shift, KEY0 ->

REMAPPING shift, B -> UP
REMAPPING shift, D -> RIGHT
REMAPPING shift, F -> END
REMAPPING shift, H -> >
REMAPPING shift, J -> EXCLAMATION
REMAPPING shift, L ->)
REMAPPING shift, N -> QUESTION
REMAPPING shift, P ->]
REMAPPING shift, R -> AT
REMAPPING shift, T -> DOLLAR
REMAPPING shift, V -> SLASH
REMAPPING shift, X -> ADD
REMAPPING shift, Z -> STAR
#REMAPPING shift, KEY7 ->
#REMAPPING shift, KEY9 ->
#REMAPPING shift, KEY5 ->
#REMAPPING shift, KEY1 ->
#REMAPPING shift, KEY3 ->

30-Key Key Map

31 Key JettCE keyboard definition file

The keyword "FUNCTION" is used for the "2nd" key.
The keyword "RETURN" is used for the "ENTER" key.
"USER_DEF1" defines the Contrast+ key
"USER_DEF2" defines the Contrast- key
"USER_DEF3" defines the Backlight-INCREASE key
"USER_DEF4" defines the Backlight-DECREASE key
"WINMENU" produces the Windows "Start" menu.

The line and the end of the line
ROWS 10
COLS 5

The id of the keyboard.
ID 31

Table 0 is always the unshifted values.
TABLE 0, basic, UNSHIFTED
TABLE 1, shift, SHIFT

The basic scan codes.
Row,Col,Scan Code

SCANCODE 0, 0 -> A	SCANCODE 0, 1 -> B	SCANCODE 0,2 -> C
SCANCODE 1, 0 -> D	SCANCODE 1, 1 -> E	SCANCODE 1,2 -> F
SCANCODE 2, 0 -> G	SCANCODE 2, 1 -> H	SCANCODE 2,2 -> I
SCANCODE 3, 0 -> J	SCANCODE 3, 1 -> K	SCANCODE 3,2 -> L
SCANCODE 4, 0 -> M	SCANCODE 4, 1 -> N	SCANCODE 4,2 -> O
SCANCODE 5, 0 -> P	SCANCODE 5, 1 -> Q	SCANCODE 5,2 -> R
SCANCODE 6, 0 -> S	SCANCODE 6, 1 -> T	SCANCODE 6,2 -> U
SCANCODE 7, 0 -> V	SCANCODE 7, 1 -> W	SCANCODE 7,2 -> X
SCANCODE 8, 0 -> Y	SCANCODE 8, 1 -> Z	SCANCODE 8,2 -> ESCAPE
SCANCODE 9, 0 -> SHIFT	SCANCODE 9, 1 -> SPACE	SCANCODE 9,2 -> RETURN

```

# Shift remapping table.
REMAPPING shift, A -> LEFT
REMAPPING shift, C -> RIGHT
REMAPPING shift, E -> UP
REMAPPING shift, G -> TAB
REMAPPING shift, I -> COMMA
REMAPPING shift, K -> COLON
REMAPPING shift, M -> USER_DEF4
REMAPPING shift, O -> USER_DEF3
REMAPPING shift, Q -> KEY8
REMAPPING shift, S -> KEY4
REMAPPING shift, U -> KEY6
REMAPPING shift, W -> KEY2
REMAPPING shift, Y -> ALT
REMAPPING shift, ESCAPE -> PERIOD

REMAPPING shift, B -> DOWN
REMAPPING shift, D -> SUBTRACT
REMAPPING shift, F -> ADD
REMAPPING shift, H -> QUESTION
REMAPPING shift, J -> BACKSLASH
REMAPPING shift, L -> SLASH
REMAPPING shift, N -> STAR
REMAPPING shift, P -> KEY7
REMAPPING shift, R -> KEY9
REMAPPING shift, T -> KEY5
REMAPPING shift, V -> KEY1
REMAPPING shift, X -> KEY3
REMAPPING shift, Z -> KEY0
REMAPPING shift, SPACE -> BACKSPACE

```

15-Key Key Map

```

# Copyright (c) 2003 TURCK Corporation. All rights reserved.
# File: JET15Key.txt
#
# 15 Key JETT.ce keyboard, REV 1
# The keyword "FUNCTION" is used for the "2nd" key.
# The keyword "RETURN" is used for the "ENTER" key.
# "USER_DEF1" defines the Contrast+ key
# "USER_DEF2" defines the Contrast- key
# "USER_DEF3" defines the Backlight-On key
# "USER_DEF4" defines the Backlight-Off key
# "WINMENU" produces the Windows "Start" menu.

# The number of rows and columns.
# Note: COLS MUST ALWAYS be a 5
ROWS 5
COLS 5

# The id of the keyboard.
ID 15

# The basic scan codes.
#      Row,Col,Scan Code
SCANCODE 0, 0 -> TAB          SCANCODE 0, 1-> UP          SCANCODE 0,2 -> ALT
SCANCODE 1, 0 -> LEFT        SCANCODE 1, 1-> BACKSLASH  SCANCODE 1,2 -> RIGHT
SCANCODE 2, 0 -> SUBTRACT    SCANCODE 2, 1-> DOWN       SCANCODE 2,2 -> ADD
SCANCODE 3, 0 -> ESCAPE      SCANCODE 3, 1-> PERIOD     SCANCODE 3,2 -> RETURN
SCANCODE 4, 0 -> FUNCTION    SCANCODE 4, 1-> CONTRO    SCANCODE 4,2 -> SPACE

# Table 0 is always the unshifted values.
TABLE 0, basic, UNSHIFTED
TABLE 1, func, FUNCTION
TABLE 2, shift, SHIFT

# func remapping table.
REMAPPING func, TAB          -> KEY1
REMAPPING func, ALT          -> KEY3
REMAPPING func, BACKSLASH    -> KEY5
REMAPPING func, SUBTRACT     -> KEY7
REMAPPING func, ADD          -> KEY9
REMAPPING func, PERIOD       -> KEY0
REMAPPING func, RETURN      ->
USER_DEF3

REMAPPING func, UP          -> KEY2
REMAPPING func, LEFT       -> KEY4
REMAPPING func, RIGHT      -> KEY6
REMAPPING func, DOWN       -> KEY8
REMAPPING func, ESCAPE     -> USER_DEF4
REMAPPING func, RETURN     ->

```

Index

1

1210 Series Modular Cable	2-5, B-2
15-Key Key Map.....	C-4
15-Key Keypad.....	3-6

2

2ND Key	3-7
2ND Mode	3-7

3

30-Key Key Map.....	C-3
30-Key Keypad.....	3-6

4

45-Key Key Map.....	C-2
45-Key Keypads	3-6

A

About RFID.....	1-1
About the <i>BL ident</i> -Handheld	1-2
About this Manual	1-1
ActiveSync	5-1
Allowed Values in Key Map Files	C-1
ALT Key	3-7
Aux Switch	4-1

B

Backlight	4-1
Battery Compartment.....	2-2
Battery Indicator	2-1
Battery Select	4-1
Beep Select	4-1
Bluetooth Device Properties	4-1

C

Cable Connections.....	2-5
Case Dimensions	A-2
CE Keyboard.....	3-7
CeKeys	3-7
CELAT-P Adapter.....	2-5, B-3
Certificates.....	4-1
Changing System Settings.....	4-3
Charge\Low Battery Indicator.....	3-2
Charge\Low Battery Indicator Functions.....	3-2
Charging the Unit.....	3-1
CHG Indicator	3-2
Compact Flash Slot Cover	2-3
Connecting to a Mail Server.....	4-7
Control Panel	4-1
Control Panel Functions	4-1
CPU Specifications	A-1
CPU Speed.....	4-1
Creating a Wired Ethernet Network Connection.....	4-6
CTRL Key	3-7

D

Data Entry	3-8
Date/Time.....	4-1
Desktop Functions.....	3-9
Development Tools	5-1
Dialing	4-1
Display.....	2-1, 4-1
Display Rotation.....	4-1
Display Specifications.....	A-1
Displays	1-3
Durability	1-3

E

Environmental Specifications	A-1
------------------------------------	-----

F	
Front Components and Indicators.....	2-1
Fully/Near Full Charge	3-2

H	
High Power Charge	3-2
Hot Keys	4-1

I	
Inbox	3-9
Indicator Specifications	A-2
Indicators	1-3
Input Panel	4-2
Interface Capabilities	1-3
Interface Specifications.....	A-2
Internet Explorer	3-9
Internet Options	4-2

K	
Key Repeat	3-7
Keyboard.....	4-2
Keyboard Mapping.....	5-34
Keyboard Mapping Files.....	C-1
Keyboard Mapping Files Notes	C-1
Keypad	2-1
Keypads.....	1-3, 3-6

L	
LEDs	2-1, 5-13
LOW BAT Indicator.....	3-2

M	
Memory and Mass Storage	1-2
Memory and Mass Storage Specifications	A-1
Modifier Keys	3-6
Modular Cable Adapters	B-3
Modular to DE-9S Adapter.....	2-5
Modular-to-Modular Cable	2-5
My Computer	3-9
My Documents	3-9

N	
Network and Dial-up Connections.....	4-2
Network Connections.....	4-6
Null Modem Cable	B-3

O

On/Off Switch.....	2-1
Operating System.....	1-2
Operation.....	3-1
Overview.....	1-1
Owner.....	4-2

P

Partnership.....	4-9
Password.....	4-2
PC Connection.....	4-2
Persistent Registry.....	4-12
Physical Dimensions.....	A-2
Power.....	3-1, 4-2
Power Management.....	3-4
Power Off.....	3-4
Power On.....	3-3
Power Requirements.....	A-1
Power Status Icons.....	3-10
Power Supply.....	2-5, A-1
Power/Suspend Switch.....	3-3
Processor.....	1-2

R

Rechargeable Battery Pack.....	1-2
Recycle Bin.....	3-9
Regional Settings.....	4-2
Remove Programs.....	4-2
Resetting the Registry.....	4-13
RFID Module.....	2-2
RFID Read Range.....	3-8

S

Saving Changes to the Registry.....	4-12
Setting Up Identification for Remote Networks.....	4-7
SHIFT Key.....	3-7
Shift Mode.....	3-7
Signal and Pin Assignments.....	B-1

Specifications.....	A-1
Start Menu.....	3-10
Storage Manager.....	4-2
Stylus.....	4-2
Suspend Function Control.....	5-13
Suspend Mode.....	3-4
System.....	4-2
SystemCF Folder.....	3-10

T

Taskbar.....	3-9
Taskbar and Start Menu Settings.....	4-4
The Windows CE .NET Desktop.....	3-9
Trickle Charge.....	3-2
Troubleshooting.....	6-1

U

User Input Specifications.....	A-1
Using ActiveSync.....	4-9
Initial Communication.....	4-9
Subsequent Communication.....	4-12
Using the Compact Flash Slot.....	4-5
Using the RFID Module.....	3-8

V

VComAdj.....	4-2
--------------	-----

TURCK

Industrial
Automation



www.turck.com

Hans Turck GmbH & Co. KG
45472 Mülheim an der Ruhr,
Germany
Witzlebenstraße 7
Tel. +49 (0) 208 4952-0
Fax +49 (0) 208 4952-264
E-Mail more@turck.com
Internet www.turck.com



D101585 0406