

TURCK

Industrial
Automation

**FOUNDATION™
FIELDBUS**

**DIAGNOSTIC
POWER
CONDITIONER
SYSTEM
"DPC-49-
4RMB/SY"**

USER MANUAL



All brand and product names are trademarks or registered trade marks of the owner concerned.

Edition 11/08

© Hans Turck GmbH, Mülheim an der Ruhr

All rights reserved, including those of the translation.

No part of this manual may be reproduced in any form (printed, photocopy, microfilm or any other process) or processed, duplicated or distributed by means of electronic systems without written permission of Hans Turck GmbH & Co. KG, Mülheim an der Ruhr.

Subject to alterations without notice.

0 About this manual

Descriptions of used symbols.....	0-2
Introduction.....	0-2

1 Introduction

Performance characteristics	1-2
Expanded diagnostics	1-2
Simple diagnostics	1-4
System overview.....	1-4
Diagram backplane DPC-49-4RMB/SY (populated)	1-5

2 Mounting and installation

General safety instructions.....	2-2
Mounting - brief instruction.....	2-2
Dimensional drawings.....	2-3
Mounting.....	2-3
Demounting	2-4
Connections and population of the DPC-49-4RMB/SY	2-5
DPC-49-IPS1	2-5
Dummy modules for unpopulated slots	2-6
H1-connections to the host	2-7
H1-connections to the field	2-7
Power supply	2-7
Connection concepts	2-9
Redundancy.....	2-9
Switch functionality.....	2-10
Connection diagrams	2-11
Shielding.....	2-13
Grounding	2-14
LEDs of the DPC-49-IPS1 module	2-14

Warning!

Dangerous electrical voltage!

Before beginning installation work

- Disconnect the device from the power supply
- Protect against accidental restart
- Verify isolation from the supply
- Earth and short-circuit the supply
- Cover or close off neighbouring units that are live.
- The assembly instructions provided for the device are to be complied with.
- Only suitably qualified personnel according to EN 50 110-1/-2 (VDE 0105 part 100) are authorised to carry out work on this device/system.
- When conducting installation work ensure that you are free of electrostatic charge before touching the device.
- The functional earth (FE) must be connected to the protective earth (PE) or the equipotential bonding. The system installer is responsible for establishing this connection.
- Connection and signal cables are to be installed so that any inductive or capacitive interference does not impair the automation functions.
- The installation of automation devices and their operating elements is to be carried out in such a way as to prevent unintentional operation.
- In order to prevent cable or wire breakage on the signal side generating undefined states in the automation devices, appropriate safety measures are to be taken for the I/O coupling on the hardware and software side.
- Ensure a reliable isolation of the extra-low voltage for the 24 volt supply. Only those power supply units that comply with IEC 60 364-4-41, i.e. HD 384.4.41 S2 (VDE 0100 part 410) are to be deployed.
- Fluctuations or deviations of the mains voltage from the nominal value should not exceed the tolerance limits specified in the technical data, otherwise malfunctions and dangerous states may occur.
- Emergency stop devices complying with IEC/EN 60 204-1 must remain effective in all operating modes of the automation installation. Releasing the emergency stop devices must not cause a restart.
- Devices for mounting in housings or cabinets, desktop or portable units, are only to be operated and controlled with the housing closed.
- Measures are to be taken to ensure the correct restarting of a program following interruption due to a voltage drop or failure. Dangerous operating conditions, even short term, should not occur as a result. If required an emergency stop should be carried out.
- External measures are to be implemented at those locations where faults in the automation installation could lead to injury to persons or damage to property. These measures must guarantee safe operating conditions even in the event of a fault or malfunction (e.g. by means of independent limit switches or mechanical locking devices etc.).
- The electrical installation must be carried out in accordance with the relevant regulations (e.g. in respect of the cable cross sections, uses and protective earth connections).
- All work involving transport, installation, commissioning and maintenance is to be carried out exclusively by qualified personnel. (in accordance with IEC 60 364 i.e. HD 384 or DIN VDE 0100 and national accident prevention regulations).
- All covers and doors must be kept closed during operation.

0 About this manual

Descriptions of used symbols	2
Introduction	2

Descriptions of used symbols



Warning

This symbol is positioned next to warnings that indicate a source of danger. This may involve personal injury and system damage (hardware and software).

For the user this symbol means: Please use extreme caution when proceeding to work.



Attention

This symbol is positioned next to warnings that indicate a potential source of danger.

This may involve possible personal injury and damage to systems (hardware and software) and installations.



Note

This symbol is positioned next to the general instructions that point out important information concerning one or more operating steps.

The respective instructions may facilitate the work and help avoid additional work caused by the wrong operating steps, for example.

Introduction

This manual contains the necessary information for the intended use of the TURCK products for the FOUNDATION™ fieldbus-system "Diagnostic Power Conditioner". It was specifically developed for qualified personnel with the required technical know-how.

The first chapter serves as a product introduction and describes the product's most basic features.

Chapter 2 provides support for professional mounting and installation.



Warning

The devices described in this manual must only be used for the intended applications found in this manual and the respective technical description, and only in connection with certified OEM devices and OEM components.

The correct and safe operation of the devices is based on the proper transport, storage, assembly and installation, as well as careful user operation and maintenance.



Warning

It is imperative that the safety and accident prevention regulations for the respective application are adhered to.

1 Introduction

Performance characteristics	2
Expanded diagnostics	2
– Functionality	2
Simple diagnostics	4
System overview	4
Diagram backplane DPC-49-4RMB/SY (populated)	5

Performance characteristics

The DPC-system (Diagnostic Power Conditioner System) is a power supply system for the assembly of FOUNDATION™ fieldbus H1-segments.

It provides comprehensive diagnostic possibilities for monitoring FOUNDATION™ fieldbus-segments and therefore supports system-wide asset management.

For example, a DPC-system consists of one or more backplanes DPC-49-4RMB/SY... with up to eight power supply modules each DPC-49-IPS1. Per backplane up to four H1-segments may be redundantly operated and monitored in the FOUNDATION™ fieldbus.

The diagnostic data from the H1-segments are collected via a diagnostic module (DPC-49-ADU) which is plugged into the backplane and then transferred to the intelligent HSE-field device DPC-49-HSEFD/24VDC. The raw data is processed in the DPC-49-HSEFD/24VDC and transferred to the higher asset management system.

For basic redundancy monitoring of the power supply modules, only the diagnostic module (DPC-49-DU) is needed which signals an alarm via a relay contact.

Expanded diagnostics

Turck developed the FOUNDATION™ fieldbus Diagnostic Power Conditioning System (DPC-System) for the long-term detection of interferences on a H1 FOUNDATION™ fieldbus-segment. Next to the start-up support of a fieldbus system, the DPC system primarily shall detect subtle changes within single fieldbus segments over a long period of time and prevent interferences and even failures with the help of appropriate alarm signals.

With the FOUNDATION™ fieldbus-HSE-Field-Device developed by TURCK, diagnostic data relating to the Physical Layer of up to 16 H1-segments are made accessible to the asset management system.

The asset management system contains data relating to the Physical Layer of the H1-segment, whereby this asset becomes manageable in the asset management system and system availability is increased.

The physical level of the fieldbus and thus its communication may be interfered with by external influences. These external influences often cause an unexpected failure only after a longer period of time.

Examples of these types of influences are:

- Ageing of cables (possibly accelerated by moisture)
- Ageing of communication electronics
- Loosening cable connectors (especially when vibration occurs)
- Insufficient grounding and shielding which only become evident when EMC-conditions change.
- Cables with incorrect capacitive and inductive values

Functionality

Each backplane has a slot for a diagnostic module (DPC-49-ADU or DPC-49-DU). The ADU ("ADU - Advanced Diagnostics Unit" please refer to the D301167 "Diagnostics" Glossary) can consecutively multiplex the particular segments and collect many types of data. This data is sent to the intelligent HSE-field device (DPC-49-HSEFD/24VDC) where it is evaluated.

This is measured:

- Ambient temperature of the system
- External power supply 1
- External power supply 2
- Level of the segment current
- LAS-signal level
- Noise voltage
- Jitter
- Ripple
- Lowest signal level
- Highest signal level
- Device address of the device with the lowest signal level

This is counted:

- Number of all received frames
- Number of CRC-errors
- Sequence error (when a Return Token Frame does not follow a Pass Token Frame)
- Number for IDLE-frames
- Number of frames which are not contained in the table "Possible frames that may follow a "Pass Token"
- Number of signals of type "Pass Token"
- Number of signals of type "Return Token"
- Number of signals of type "Time Distribution"
- Number of signals of type "Compel Data"
- Number of signals of type "Data_1 / Data_2"
- Number of signals of type "Data 3 and Data 5"
- Number of signals of type "Disconnect Connection"
- Number of signals of type "Establish Connection"

This is determined:

- Number of active H1-devices on a H1-segment
- Bus load via "Link Maintenance Frames"
- Bus load via "Cyclic Frames"
- Bus load via "Acyclic Frames"
- Bus load via "Idle Frame"
- Share of unused bus time "Idle Time"

**Note**

Explanations of the measurement values, signal types and frames can be found in the glossary of the D301167 "Diagnostics" manual.

Introduction

These values can be sent to a higher asset management system via FF-HSE. For each parameter, preliminary alarms and main alarms are parameterized in the DPC-49-HSEFD/24VDC. If a limit value is overreached or underreached, a FF-alarm can be automatically sent via HSE. The relay for signalling the group interference drops out for the time the limit value is overreached or underreached.

For the startup of the DPC-system with the FDT-technology, TURCK provides the DTM ("DTM - Device Type Manager" please refer to the D301167 "Diagnostics" glossary) for the DPC-49-HSEFD/24VDC.

If the DPC-system is to be integrated into a control system with the help of a FOUNDATION™ fieldbus HSE-configurator, TURCK provides a Device Description ("DD - Device Description" please refer to the D301167 "Diagnostics" glossary).

Simple diagnostics

If the requirement is limited to redundancy monitoring of the power supply modules (DPC-49-IPS1) and the external power supply, only the diagnostic module (DPC-49-DU) is needed which signals an alarm via a relay contact.

System overview

Figure 1:
System
overview with
expanded
diagnostics

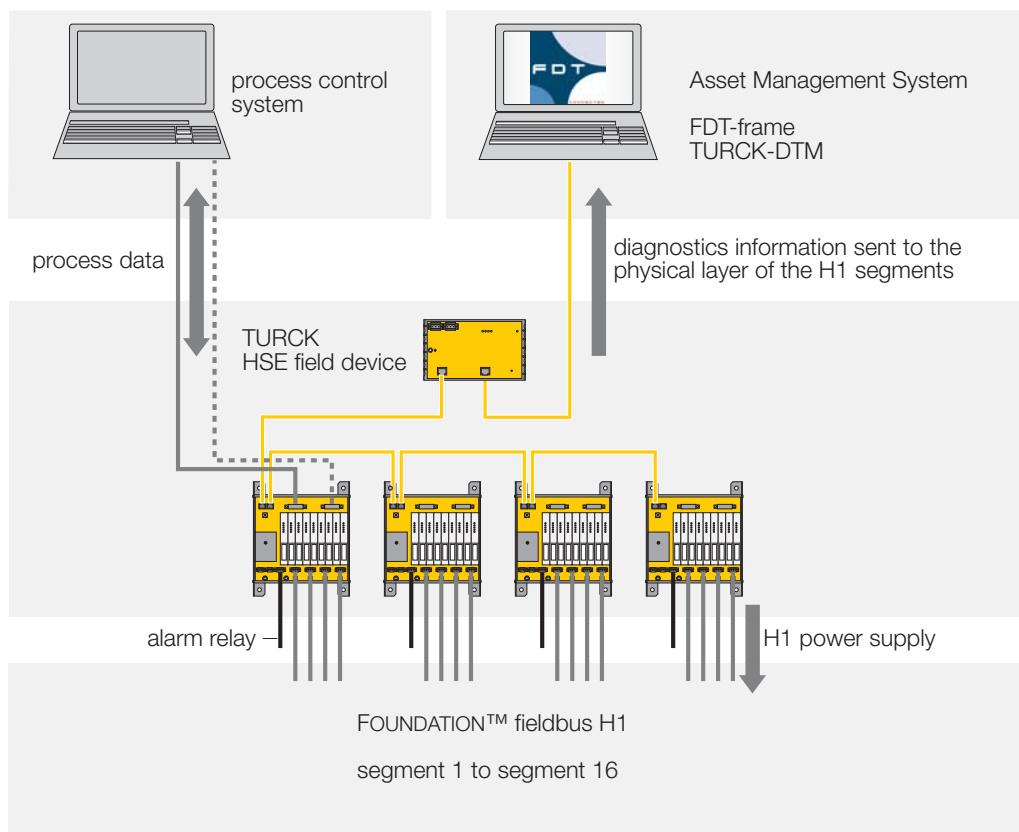
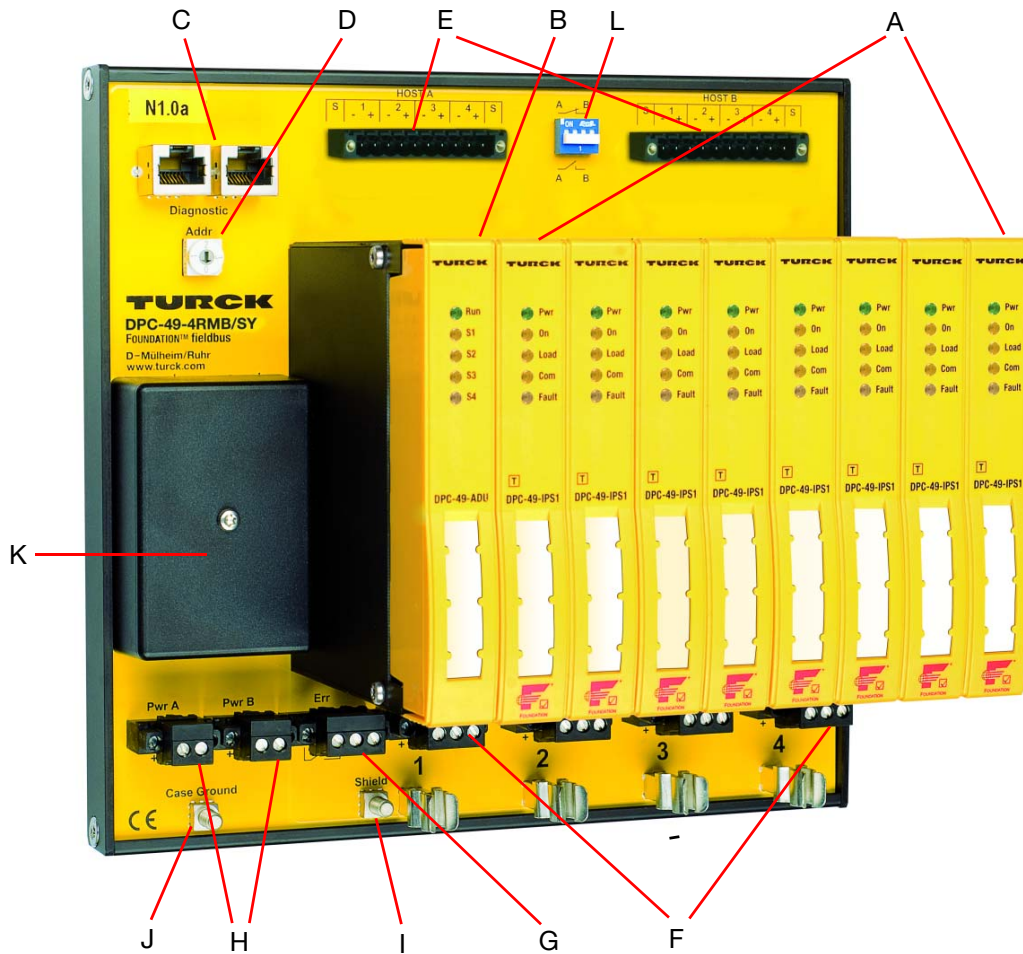

Diagram backplane DPC-49-4RMB/SY (populated)

Figure 2:
DPC-49-4RMB/
SY with legend



- A** ["DPC-49-IPS1" page 2-5](#)
- B** Slot for the diagnostic modules "DPC-49-ADU" or "DPC-49-DU"*
- C** Connection for "Diagnostic Bus"*
- D** "Address switch "Addr." for diagnostic bus*
- E** ["H1-connections to the host" page 2-7](#)
- F** ["H1-connections to the field" page 2-7](#)
- G** Connection for the "Interference Alarm Relay"*
- H** ["Power supply" page 2-7](#)
- I** Shield connection - ["Shielding" page 2-13](#)
- J** Connection of the housing - potential equalization - ["Grounding" page 2-14](#)
- K** Overvoltage protection and EMC-filter
- L** Switch for selecting the redundancy concept

*)please refer to the manual D301167 "Diagnostics"

2 Mounting and installation

General safety instructions	2
Mounting - brief instruction	2
Dimensional drawings.....	3
Mounting.....	3
Demounting	4
Connections and population of the DPC-49-4RMB/SY	5
DPC-49-IPS1	5
Dummy modules for unpopulated slots	6
H1-connections to the host	7
H1-connections to the field	7
Power supply	7
– EMC-filter and overvoltage protection	9
Connection concepts	10
Redundancy.....	10
Switch functionality.....	10
Connection diagrams	12
Shielding	14
Grounding	15
LEDs of the DPC-49-IPS1 module	15

Mounting and installation

General safety instructions



Warning

When mounting and installing, please observe that the limit values of the connection data are not exceeded at any time!

Mounting - brief instruction

Use the following brief instruction for mounting the DPC to feed power to the H1-segments:

Required components:

- backplane DPC-49-4RMB/SY
 - Power supply module DPC-49-IPS1
 - Dummy modules for unpopulated slots (BM-DPC)
- 1** Populate the backplane with one or two (redundancy) modules of type ["DPC-49-IPS1" page 2-5](#) for each segment.
 - 2** Connect the power supply to the backplane (DPC-49-4RMB/SY)(["Power supply" page 2-7](#)).
 - 3** Connect the ["H1-connections to the host" page 2-7](#).
 - 4** Connect the field-side H1-connections (["H1-connections to the field" page 2-7](#)).

Dimensional drawings

Figure 3:
Dimensional
drawing for the
DPC-49-4RMB/
SY

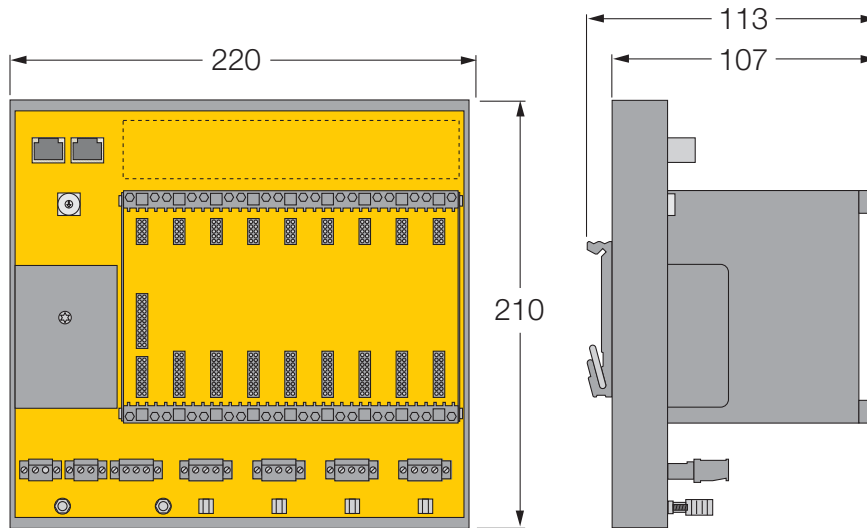

Mounting

To mount the DPC-49-4RMB/SY, push the nut of the backplane onto the mounting rail from the bottom (1). Here, the backplane should slightly tilt to the front.

Press the backplane against the mounting rail until the snap-fit latches in a way that is noticeable (2). Here, the bottom nut and groove must be slightly pressed together.

Figure 4:
Latching of the
DPC-49-4RMB/
SY onto the
mounting rail

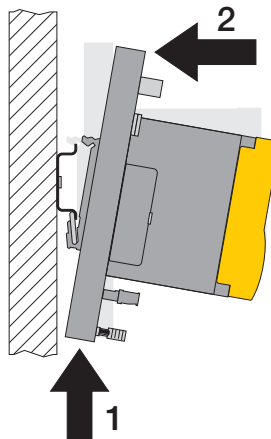

Demounting

For demounting, push the DPC-49-4RMB/SY to the top. This is how you push the bottom groove together (1). The upper snap-fit can be easily pulled from the mounting rail. The DPC-49-4RMB/SY may be tilted to the front and pushed off the mounting rail with a movement to the bottom (2).

Figure 5:
Removing the
DPC-49-4RMB/
SY from the
mounting rail

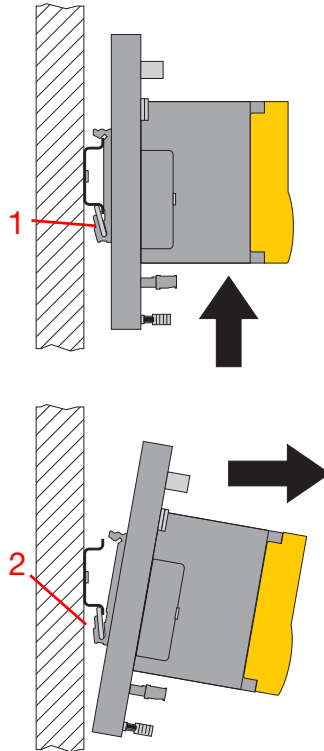

Connections and population of the DPC-49-4RMB/SY

The backplane DPC-49-4RMB/SY is designed to accommodate up to eight power supply modules and one diagnostics module. All connection terminals and ground bolts are positioned on the backplane.

Figure 6:
Unpopulated
backplane DPC-
49-4RMB/SY



DPC-49-IPS1

The DPC-49-IPS1 module is a galvanically isolated power supply module for FOUNDATION™ fieldbus (Isolated Power Supply).

Figure 7:
Power supply
module DPC-
49-IPS1



Mounting and installation

The power supply modules DPC-49-IPS1 contain the functional part of the system, this means decoupling of the H1-segment power supply from the external power supply, creation of the power supply and current limiting for the H1-segment, as well as galvanic isolation from the external power supply, from the other H1-segments and from the H1-diagnostics.



Note

With the TURCK DPC-system the quality of the modulated data on the H1-segment remains unchanged!

The power supply modules DPC-49-IPS1 are operated on the backplane. A H1-segment can be redundantly supplied by two power supply modules.

Each DPC-49-IPS1 module terminates a H1-segment with the help of the integrated terminating resistor.

The modules are plugged onto the backplane in the respective position ([see designation "A", overview page 1-5](#)). The latching tips must latch onto the rail in a noticeable manner.

Dummy modules for unpopulated slots

Unpopulated slots should be populated with "BM-DPC" dummy modules.

Figure 8:
Dummy module
BM-DPC



H1-connections to the host

The connection to the higher-level host system is via 10-pole, removable screw connectors with threaded flange: (figure "DPC-49-4RMB/SY with legend" page 1-5). The host connectors are redundantly designed.

Figure 9:
Connector pin assignment to host

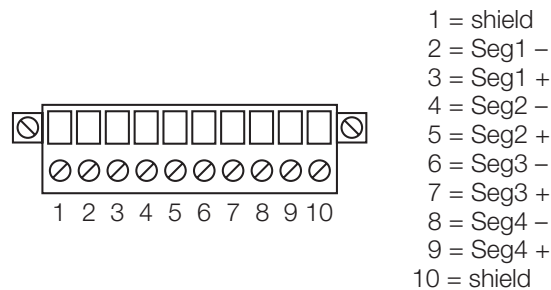

H1-connections to the field

The field-side connection occurs via four 3-pole, unpluggable screw connectors with threaded flange ((connection cross-section 0,2...4 mm²) (see designation "F", overview page 1-5)

Figure 10:
Pin assignment of the 3-pole, unpluggable screw connector with threaded flange

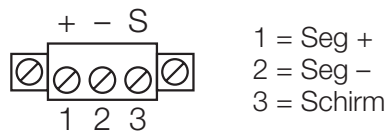

Power supply

The power can be redundantly fed ("Connection concepts" page 2-9). The connection occurs via 2-pole, unpluggable screw connectors with threaded flange (connection cross-section 0,2...4 mm²). (see designation "H", overview page 1-5)

Figure 11:
Pin assignment of the 2-pole, unpluggable screw connector with threaded flange

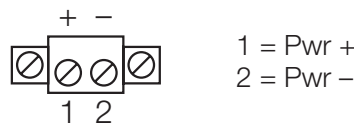

Note

The required voltage is between 18 VDC and 32 VDC.

EMC-filter and overvoltage protection

All type of connections to the power supply cables are protected with the help of EMC-filters which have the following functionalities:

- Inverse polarity protection and overvoltage protection up to 60 V
- Overvoltage shutoff (off: ≈ 36 V, on: ≈ 33 V)

The EMC-filters are covered with a black plastic plug.



Note

Defective filters may be replaced. In this case, remove the black plastic plug which is affixed with a screw!



Attention

When replacing the filter, the correct installation direction must be observed because otherwise, the system may be damaged!

Connection concepts

The DPC-49-4RMB/SY is designed for the "Single" and/or "Redundancy Operation".

Here, "Single" means only one power supply is connected, only one power supply module is plugged for each segment, and only one host system is available.

Redundancy

The following areas can be redundantly designed, and therefore failure protection is realized:

■ **External power supply**

In this case, two power supplies must be available which are connected to both of the 2-pole connectors "Pwr A" and "Pwr B".

■ **Power supply modules for the segments**

Two DPC-49-IPS1 modules are plugged to supply one segment with power.



Attention

The left power feed "Pwr A" supplies the left power supply modules of a segment. The right power feed "Pwr B" supplies the right power supplies of a segment.

■ **Host-systems**

Here, two connection assemblies must be available. To realize a redundancy operation, the DPC-49-4RMB/SY backplane has two connectors ("Host A" and "Host B") and one switch to isolate the two systems.

Figure 12:
Redundancy
concept with
switch for
isolating
redundant host
systems

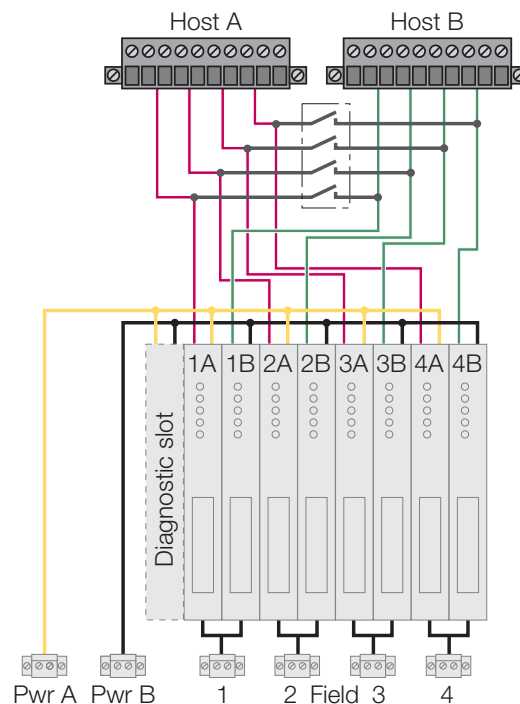

Switch functionality

The following diagram shows the switch (see designation "L", overview page 1-5) in the position "on". In this switch position, the connections "Host A" and "Host B" are isolated from each other.

"Host A" is connected to "SegmentxA", and "Host B" is connected to slot "SegmentxB".

This setting is to be selected when a redundancy of the host system/redundancy of the H1-Cards is utilized. Each field bus cable is connected to the DPC-system. The power supply modules are redundantly plugged.

Figure 13:
Switch position
"bottom" -
switch on



A **off** switch (see designation "L", overview page 1-5) connects the "Host A"-connection to the "Host B"-connection. Both connections are connected via the slot "SegmentxA" and the slot "SegmentxB".

This setting is to be selected when one host-system with or without redundancy is utilized and the H1-Card is connected with only one field bus cable. The power supply modules are redundantly plugged.

As an alternative, the host-system may be connected to "Host A" or "Host B".

Figure 14:
Switch position
"top" - switch
off



Connection diagrams

Connect your DPC-49-4RMB/SY-system per the following diagram if you desire to realize a redundancy of the power supply of the segments by only using one connection assembly:

Figure 15:
Redundancy of
the power
supply modules

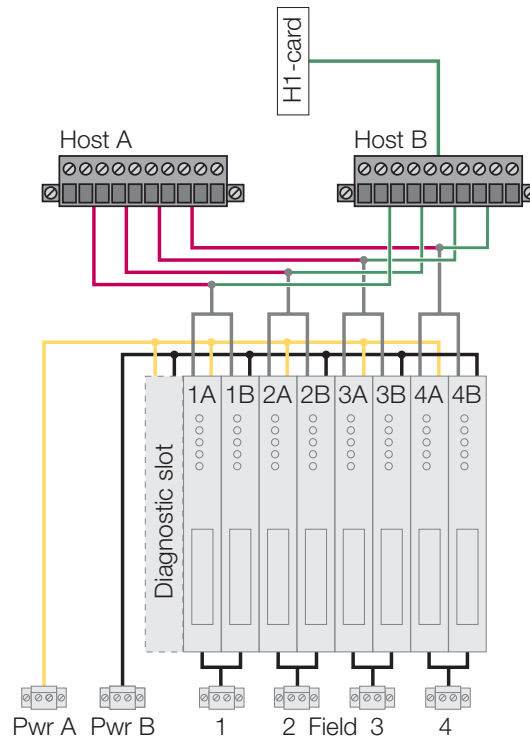

Note

The switch must be in the switch position "top" and therefore switched off!



Note

The connection assembly may be connected to "Host A" or "Host B"!

Mounting and installation

If you would like to establish a redundancy on the host-side as well, please connect the DPC-49-4RMB/SY-system per the following diagram:

Figure 16:
Redundancy of
the host-side
and the power
supply modules

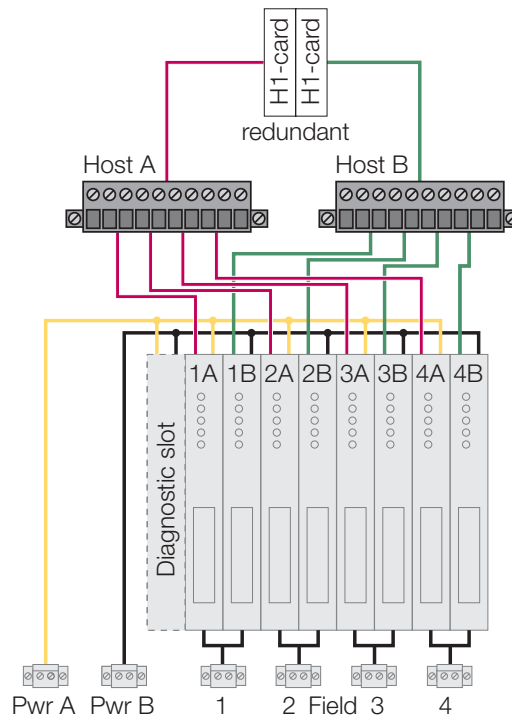

Note

The switch must be in the switch position "bottom" and therefore switched on!

Shielding

The below diagram shows the internal shield potential (yellow) of the DPC-49-4RMB/SY.

To connect the shield potential equalization, a threaded bolt M5 is available which is connected to the shield groove, the connectors and the diagnostics bus. Shielding is done by placing the shield onto the shield grooves (figure "Correctly stripped cable with cable end sleeve for optimum protection of the braided shield and positioning onto the shield groove." page 2-13) or alternatively by connecting the drain wire to the connector.

Figure 17:
Shield potential
of the DPC-49-
4RMB/SY

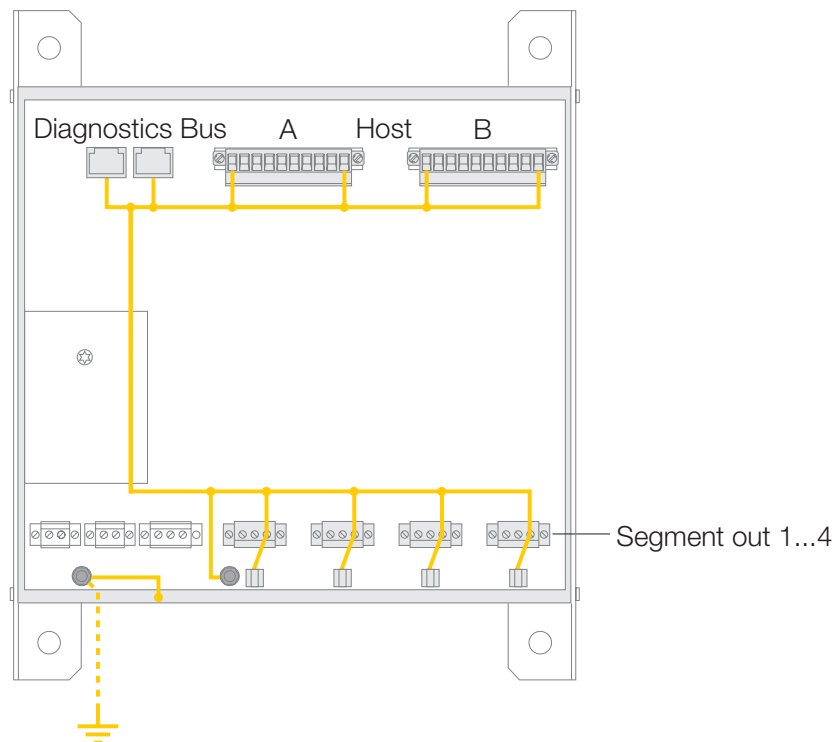

The following diagrams show a correctly stripped cable and the positioning of the shield onto the shield groove.

In order to protect the sensitive braided shield, we recommend to use a cable end sleeve for the shield as shown in the following diagram. The Figure 19 shows positioning of the shield without the cable end sleeve.

Figure 18:
Correctly
stripped cable
with cable end
sleeve for
optimum
protection of the
braided shield
and positioning
onto the shield
groove.

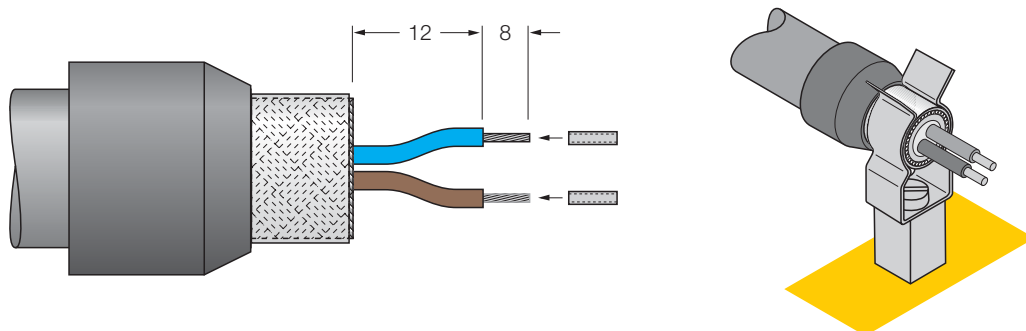

Mounting and installation

Figure 19::
Correctly
stripped cable
and positioning
onto the shield
groove.

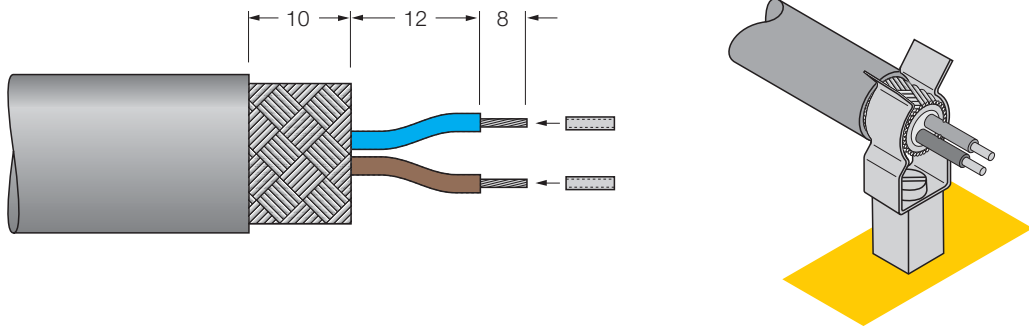

Grounding

To connect the potential equalization, a threaded bolt (see designation "J", overview page 1-5) is available. The potential equalization is connected to the metal housing components. The potential equalization is not connected to the shield potential.

LEDs of the DPC-49-IPS1 module

Table 1:
LED
diagnostics

LED	Behavior	Function
Pwr	OFF	The module has no power supply.
	Green	The power supply of the module is ok.
On	OFF	The output is switched off.
	Yellow	The output is switched on.
Load	OFF	No field devices are connected. There is no load current flow.
	Yellow	Field devices are connected. There is a load current flow of > 10 mA.
Com	OFF	H1-communication does not exist.
	Yellow	H1-communication exists.
Failure	OFF	The output voltage is ok.
	Red	The output voltage is erroneous. Overload or short-circuit on the output of the DPC-49-IPS1 module. Output current > 800 mA Output voltage < 27.5 V

TURCK

Industrial
Automation



www.turck.com

Hans Turck GmbH & Co. KG
45472 Mülheim an der Ruhr
Germany
Witzlebenstraße 7
Tel. +49 (0) 208 4952-0
Fax +49 (0) 208 4952-264
E-Mail more@turck.com
Internet www.turck.com

D301166 1108