

RI360P0-QR24M0-IOLX2-H1141/3GD

Contactless Encoder with ATEX Certificate – IO-Link, 3GD, Zone 2 (22)

Premium Line

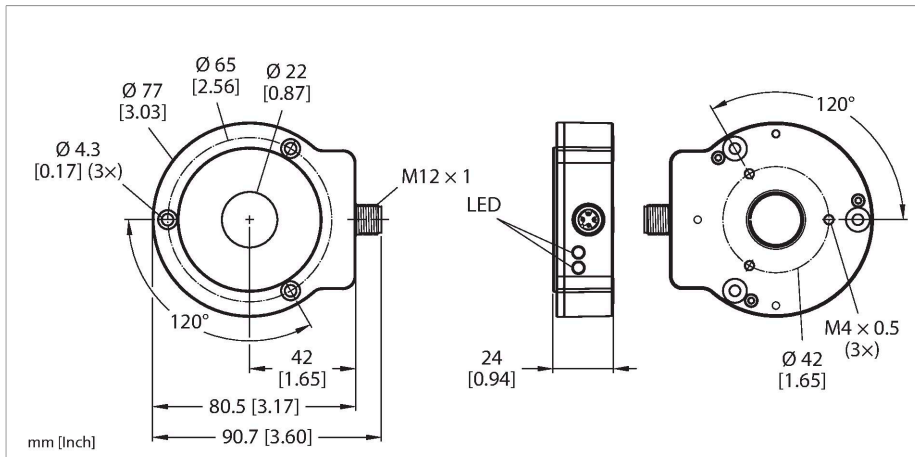

Technical data

Type	RI360P0-QR24M0-IOLX2-H1141/3GD
ID	100003122
Measuring principle	Inductive
General data	
Max. rotational speed	800 rpm
Starting torque shaft load (radial / axial)	Determined with standardized construction, with a steel shaft Ø 20 mm, L = 50 mm and reducer Ø 20 mm. not applicable, because of contactless measuring principle
Measuring range	0...360 °
Nominal distance	1.5 mm
Repeat accuracy	≤ 0.01 % of full scale
Linearity deviation	≤ 0.05 % f.s.
Temperature drift	≤ ± 0.003 %/K
Output type	Absolute semi-multiturn
Resolution singleturn	16 bit/65,536 units per revolution
Resolution multiturn	13 bit/8192 revolutions
Number of diagnostic bits	3 Bit
Electrical data	
Operating voltage U_B	24 VDC
Ripple U_{ss}	≤ 10 % U_{Bmax}
Isolation test voltage	0.5 kV
Wire break/reverse polarity protection	yes (voltage supply)
Communication protocol	IO-Link
Sample rate	1000 Hz

Features

- Compact and robust housing
- Versatile mounting options
- Status displayed via LED
- Immune to electromagnetic interference
- 16 bits singleturn
- Process value in 32 bit IO-Link telegram
- 3 error bits
- 16 bits singleturn
- 13 bits multiturn
- 15...30 VDC
- M12 × 1 male connector, 4-pin
- ATEX category II 3 G, Ex zone 2
- ATEX category II 3 D, Ex zone 22

Wiring diagram

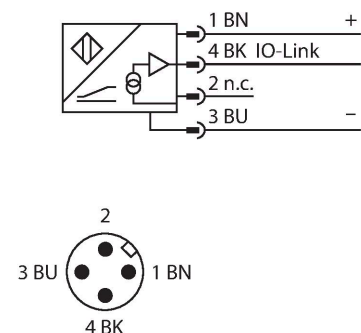

Functional principle

The measuring principle of inductive encoders is based on oscillation circuit coupling between the positioning element and the sensor, whereby an output signal

Technical data

Current consumption	< 50 mA
Approval acc. to	ATEX declaration of conformity
Device marking	II 3 G Ex ec IIA T4 Gc II 3 D Ex tc IIIC T100 °C Dc
IO-Link	
IO-Link specification	V 1.1
Programming	FDT/DTM
Communication mode	COM 2 (38.4 kBaud)
Process data width	32 bit
Minimum cycle time	3 ms
Function pin 4	IO-Link
Included in the SIDI GSDML	Yes
Mechanical data	
Design	QR24
Dimensions	81 x 78 x 24 mm
Flange type	Flange without mounting element
Shaft Type	Hollow shaft
Shaft diameter D (mm)	6 6.35 9.525 10 12 12.7 14 15.875 19.05 20
Housing material	Metal/plastic, ZnAlCu1/PBT-GF30-V0
Electrical connection	Connector, M12 × 1
Environmental conditions	
Ambient temperature	-25...+70 °C Acc. to UL approval to +70 °C
Vibration resistance	55 Hz (1 mm)
Vibration resistance (EN 60068-2-6)	20 g; 10...3000 Hz; 50 cycles; 3 axes
Shock resistance (EN 60068-2-27)	100 g; 11 ms ½ sine; 3 × each; 3 axes
Continuous shock resistance (EN 60068-2-29)	40 g; 6 ms ½ sine; 4000 × each; 3 axes
Protection class	IP68 IP69K
MTTF	138 years acc. to SN 29500 (Ed. 99) 40 °C
Power-on indication	LED, Green
Measuring range display	LED, yellow, yellow flashing
Included in delivery	MT-QR24 mounting aid
UL certificate	E210608

is provided proportional to the angle of the positioning element. Turck refers to semi-multiturn because the multiturn process data is calculated internally from the number of single-turn zero passes. Because the sensor does not detect any revolutions when not supplied with power, the plausibility of the multiturn process data is indicated by a diagnostic bit. The rugged sensors are maintenance- and wear-free thanks to the contactless operating principle. They convince through their excellent repeatability, resolution and linearity within a broad temperature range. The innovative technology ensures high immunity to electromagnetic DC and AC fields.

Mounting instructions

Mounting instructions/Description

A

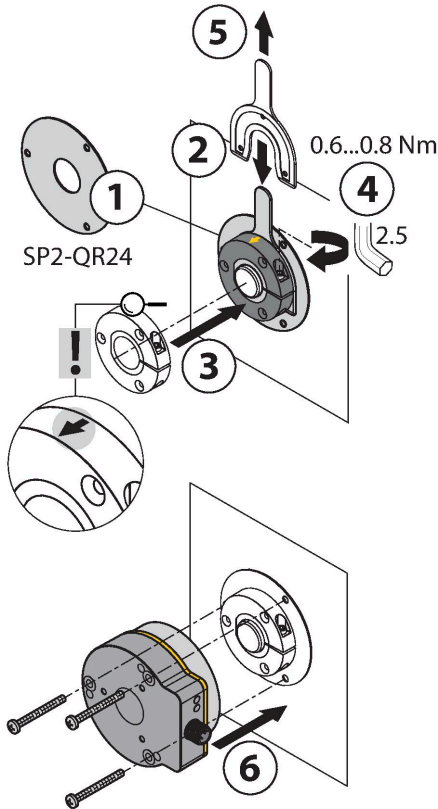

B

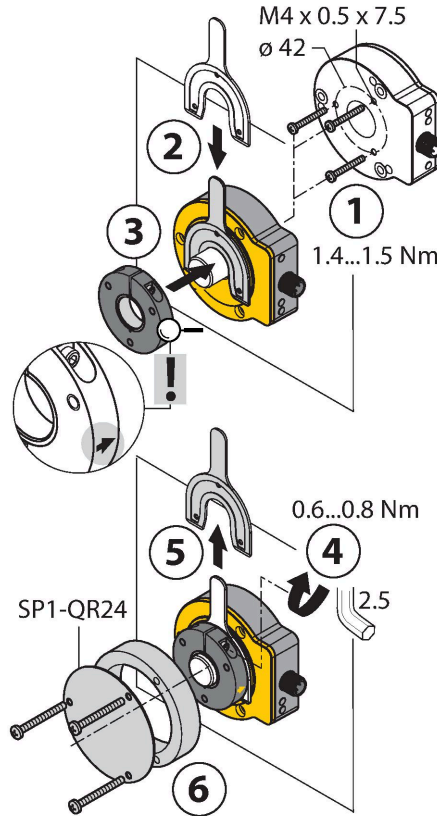

C

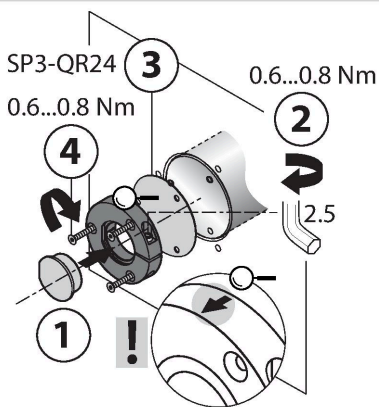

Default: 0°

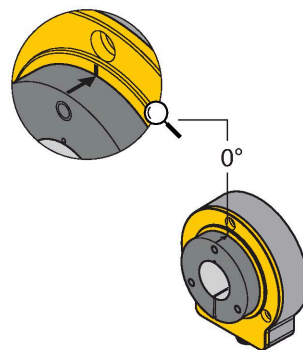

The extensive range of mounting accessories enables easy adaptation to many different shaft diameters. Due to the measuring principle, which is based on the functional principle of an RLC coupling, the encoder is immune to magnetized ferrous chips and other interferences. As a result, there are few possible causes of error during mounting. The adjacent figures show the simple installation of the two separate units: the sensor element and the positioning element: Mounting option A:

First, connect the positioning element to the rotatable shaft using the bracket. Then place the encoder with the aluminum ring above the rotating part in such a way that you get a closed and protected unit.

Mounting option B:

Slide the encoder backward onto the shaft and fasten it to the machine. Then fasten the positioning element to the shaft using the bracket.

Mounting option C:

If the positioning element is screwed onto a rotating machine part rather than being put on a shaft, you must first insert the dummy plug RA8-QR24. Then tighten the bracket. Next, mount the encoder via the three bores.

Due to the separate installation of positioning element and sensor, no electrical currents or harmful mechanical forces are transmitted to the sensor via the shaft. The encoder also offers a high degree of protection throughout its service life and stays permanently sealed. During commissioning, the accessories included in the delivery help to mount the encoder and the positioning element at an optimal distance from each other. In addition, LEDs indicate the status. Optionally, you can use the shield plates included in the accessories to increase the permitted distance between the positioning element and the sensor.

Status display via LED

Green:

Sensor is being supplied properly

Yellow:

Positioning element is within the measuring range, low signal quality (e.g. distance too great)

Yellow flashing:

Positioning element is outside the detection range

Off:

Positioning element is within the measuring range

Accessories

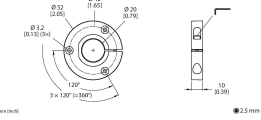
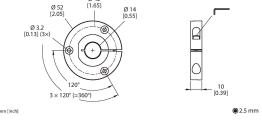
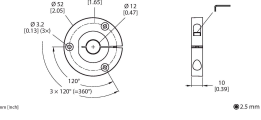
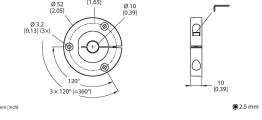
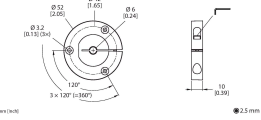
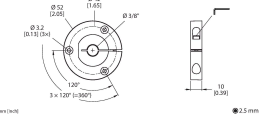
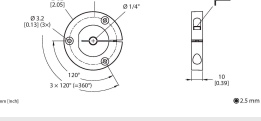
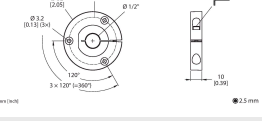
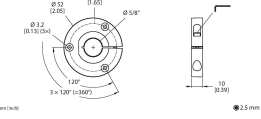
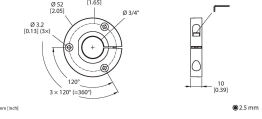
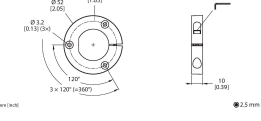
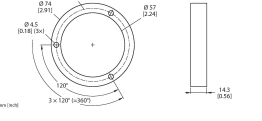
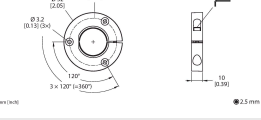
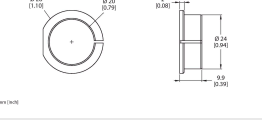
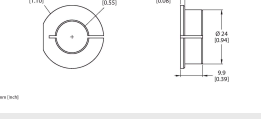
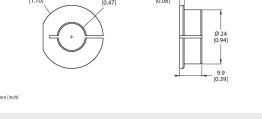
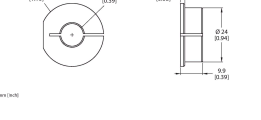
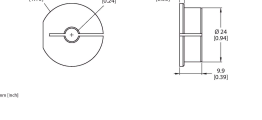
P1-RI-QR24	1590921	Positioning element, for \varnothing 20 mm shafts	P2-RI-QR24	1590922	Positioning element, for \varnothing 14 mm shafts
					
P3-RI-QR24	1590923	Positioning element, for \varnothing 12 mm shafts	P4-RI-QR24	1590924	Positioning element, for \varnothing 10 mm shafts
					
P5-RI-QR24	1590925	Positioning element, for \varnothing 6 mm shafts	P6-RI-QR24	1590926	Positioning element, for \varnothing 3/8" shafts
					
P7-RI-QR24	1590927	Positioning element, for \varnothing 1/4" shafts	P9-RI-QR24	1593012	Positioning element for installation on \varnothing 1/2" shafts
					
P10-RI-QR24	1593013	Positioning element for installation on \varnothing 5/8" shafts	P11-RI-QR24	1593014	Positioning element for installation on \varnothing 3/4" shafts
					
P8-RI-QR24	1590916	Positioning element with blanking plug for large shafts	M1-QR24	1590920	Aluminum protecting ring, for inductive encoders RI-QR24
					
PE1-QR24	1590937	Positioning element without adapter sleeve	RA1-QR24	1590928	Adapter sleeve, for \varnothing 20 mm shafts
					
RA2-QR24	1590929	Adapter sleeve, for \varnothing 14 mm shafts	RA3-QR24	1590930	Adapter sleeve, for \varnothing 12 mm shafts
					
RA4-QR24	1590931	Adapter sleeve, for \varnothing 10 mm shafts	RA5-QR24	1590932	Adapter sleeve, for \varnothing 6 mm shafts
					

RA6-QR24 1590933 Adapter sleeve, for Ø 3/8" shafts

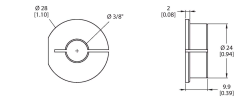

REV 16/02

RA7-QR24 1590934 Adapter sleeve, for Ø 1/4" shafts

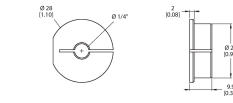

REV 16/02

RA9-QR24 1590960 Adapter sleeve, for Ø 1/2" shafts

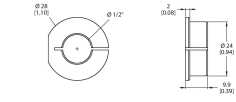

REV 16/02

RA10-QR24 1590961 Adapter sleeve, for Ø 5/8" shafts

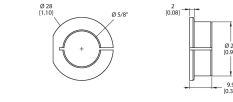

REV 16/02

RA11-QR24 1590962 Adapter sleeve, for Ø 3/4" shafts

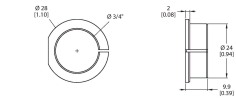

REV 16/02

RA8-QR24 1590959 Plug for mounting option C

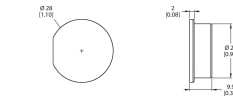

REV 16/02

SP1-QR24 1590938 Shield plate Ø 74 mm, aluminium

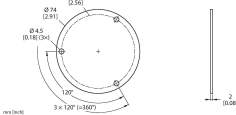

REV 16/02

SP2-QR24 1590939 Shield plate Ø 74 mm, aluminium, with borehole for shaft feedthrough

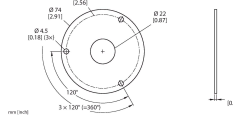

REV 16/02

SP3-QR24 1590958 Shield plate Ø 52 mm, aluminium

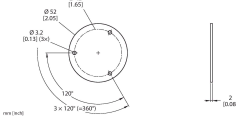

REV 16/02

MT-QR24 1590935 Mounting aid for optimal alignment of positioning element

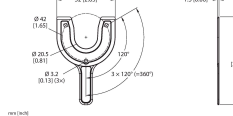

REV 16/02

Instructions for use

Intended use	In order to ensure correct operation to the intended purpose it is required to observe the national regulations and directives.
For use in explosion hazardous areas conform to classification	II 3 G and II 3 D (Group II, Category 3 G, electrical equipment for gaseous atmospheres and category 3 D, electrical equipment for dust atmospheres).
Installation/Commissioning	These devices may only be installed, connected and operated by trained and qualified staff. Qualified staff must have knowledge of protection classes, directives and regulations concerning electrical equipment designed for use in explosion hazardous areas. Please verify that the classification and the marking on the device comply with the actual application conditions.
Installation and mounting instructions	Avoid static charging of cables and plastic devices. Please only clean the device with a damp cloth. Do not install the device in a dust flow and avoid build-up of dust deposits on the device. If the devices and the cable could be subject to mechanical damage, they must be protected accordingly. They must also be shielded against strong electro-magnetic fields. The pin configuration and the electrical specifications can be taken from the device marking or the technical data sheet. In order to avoid contamination of the device, please remove possible blanking plugs of the cable glands or connectors only shortly before inserting the cable or opening the cable socket.
Special conditions for safe operation	Devices with terminal chamber (cable glands) have a weaker strain relief. Sufficient strain relief must be ensured or the cable must be stationary-mounted. Do not disconnect the plug-in connection or cable under voltage. Please attach a warning label permanently in an appropriate fashion in close proximity to the plug-in connection with the following inscription: Nicht unter Spannung trennen / Do not separate when energized. Load voltage and operating voltage of this equipment must be supplied from power supplies with safe isolation (IEC 30 364/UL508), to ensure that the rated voltage of the equipment (24 VDC +10% = 26.4 VDC) is never exceeded by more than 40%.
Service/Maintenance	Repairs are not possible. The approval expires if the device is repaired or modified by a person other than the manufacturer. The most important data from the approval are listed.