

# NI4-DS20-2Y1X2

## Inductive Sensor – For Rotary Actuators

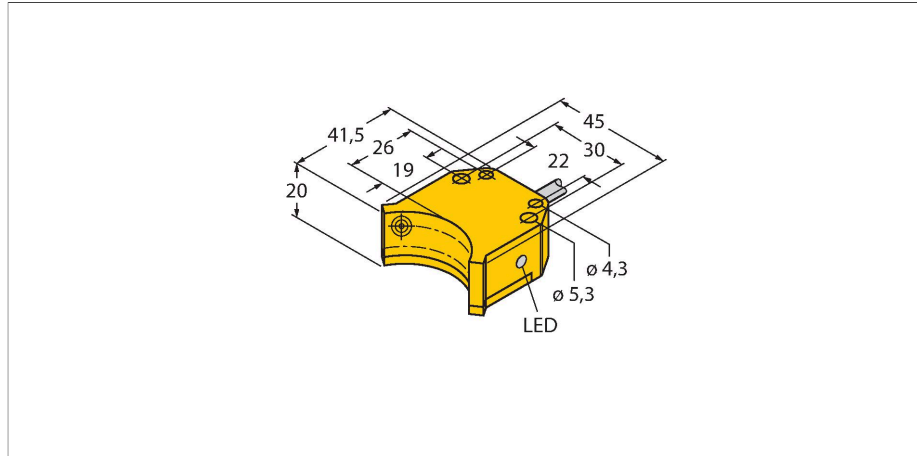

### Features

- Rectangular, housing DS20
- Plastic, PBT-GF30-VO
- Two switching outputs for monitoring the position of rotary actuators
- Mounting on all standard actuators
- DC 2-wire, nom. 8.2 VDC
- 2 outputs acc. to DIN EN 60947-5-6 (NAMUR)
- Cable connection
- ATEX category II 1 G, Ex zone 0
- ATEX category II 1 D, Ex zone 20
- SIL2 (Low Demand Mode) acc. to IEC 61508, PL c acc. to ISO 13849-1 with HFT0
- SIL3 (All Demand Mode) acc. to IEC 61508, PL e acc. to ISO 13849-1 with redundant configuration HFT1

### Technical data

Type	NI4-DS20-2Y1X2
ID	1050002
<b>General data</b>	
Rated switching distance	4 mm
Mounting conditions	Non-flush, Mounting on metal on the non-printed (rear) side permitted
Correction factors	St37 = 1; Al = 0.3; stainless steel = 0.7; Ms = 0.4
Repeat accuracy	≤ 2 % of full scale
Temperature drift	≤ ±10 %
Hysteresis	1...10 %
<b>Electrical data</b>	
Output function	4-wire, NAMUR
Switching frequency	0.05 kHz
Voltage	Nom. 8.2 VDC
Non-actuated current consumption	≥ 2.1 mA
Actuated current consumption	≤ 1.2 mA
Approval acc. to	KEMA 02 ATEX 1090X
Internal capacitance (C <sub>i</sub> )/inductance (L <sub>i</sub> )	150 nF/150 μH
Device marking	EX II 1 G Ex ia IIC T6 Ga/II 1 D Ex ia IIIC T135 °C Da (max. U <sub>i</sub> = 20 V, I <sub>i</sub> = 60 mA, P <sub>i</sub> = 200 mW)
<b>Mechanical data</b>	
Design	Dual sensor for rotary actuators, DS20
Dimensions	42 x 45 x 20 mm
Housing material	Plastic, PBT-GF30-V0
Active area material	Plastic, PBT-GF30-V0
Max. tightening torque of housing nut	3 Nm

### Wiring diagram

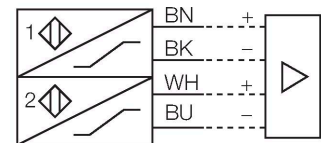

### Functional principle

Inductive sensors detect metal objects contactless and wear-free. Dual sensors are especially designed for position detection in rotary actuators. They combine the reliability of non-contact inductive sensors with the flexibility of a modular housing system.

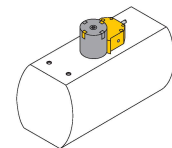

## Technical data

Electrical connection	Cable
Cable quality	Ø 5.2 mm, Blue, LifYY, PVC, 2 m
Core cross-section	4 x 0.34 mm <sup>2</sup>
<b>Environmental conditions</b>	
Ambient temperature	-25...+70 °C
Vibration resistance	55 Hz (1 mm)
Shock resistance	30 g (11 ms)
Protection class	IP67
MTTF	6198 years acc. to SN 29500 (Ed. 99) 40 °C
Switching state	2 x LEDs, Red/red

## Accessories

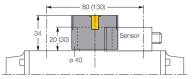
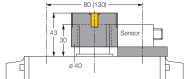
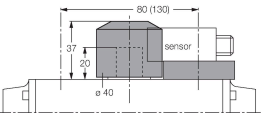
<p><b>BTS-DS20-TP1</b> 6900155</p>  <p>Actuation kit (puck) for dual sensors; end position damped; hole pattern on receptacle surface: 80 x 30 mm; connection shaft (shaft extension) height: 20 mm/Ø: max. 30 mm</p>	<p><b>BTS-DS20-TK1</b> 6900156</p>  <p>Actuation kit (puck) for dual sensors; end position damped; hole pattern on receptacle surface: 80 x 30 mm (130 x 30 mm); connection shaft (shaft extension) height: 30 mm/Ø: max. 30 mm</p>
<p><b>BTS-DS20-KEY</b> 6900136</p>  <p>Actuation kit (puck) for dual sensors; end position damped and switchpoint adjustable; hole pattern on receptacle surface: 80 x 30 mm (130 x 30 mm); connection shaft (shaft extension) height: 20 mm/Ø: max. 22 mm</p>	

## Accessories

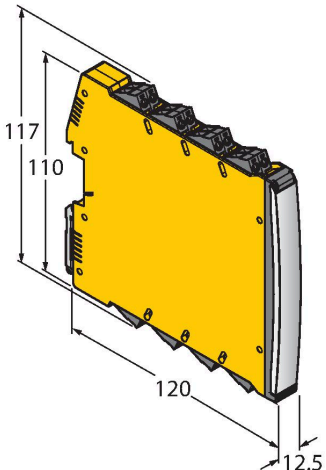
Dimension drawing	Type	ID	
	IMX12-DI01-2S-2T-0/24VDC	7580020	Isolating switching amplifier, 2-channel; SIL2 acc. to IEC 61508; Ex-proof version; 2 transistor outputs; input Namur signal; ON/OFF switchable monitoring of wire-break and short-circuit; toggle between NO/NC mode; signal doubling; removable screw terminals; 12.5 mm wide; 24 VDC power supply

## Instructions for use

Intended use	This device fulfills Directive 2014/34/EC and is suited for use in explosion-hazardous areas according to EN 60079-0:2018 and EN 60079-11:2012. It is also suitable for use in safety-related systems, including SIL2 (IEC 61508) and PL c (ISO 13849-1) with HFT0 and SIL3 (IEC 61508) and PL e (ISO 13849-1) with redundant configuration HFT1. In order to ensure that the device is operated as intended, the national regulations and directives must be observed.
For use in explosion hazardous areas conform to classification	II 1 G and II 1 D (Group II, Category 1 G, electrical equipment for gaseous atmospheres and category 1 D, electrical equipment for dust atmospheres).
Marking (see device or technical data sheet)	⊕ II 1 G and Ex ia IIC T6 Ga and ⊕ II 1 D Ex ia IIIC T135 °C Da acc. to EN 60079-0, -11
Local admissible ambient temperature	-25...+70 °C
Installation/Commissioning	These devices may only be installed, connected and operated by trained and qualified staff. Qualified staff must have knowledge of protection classes, directives and regulations concerning electrical equipment designed for use in explosion hazardous areas. Please verify that the classification and the marking on the device comply with the actual application conditions.  This device is only suited for connection to approved Exi circuits according to EN 60079-0 and EN 60079-11. Please observe the maximum admissible electrical values. After connection to other circuits the sensor may no longer be used in Exi installations. When interconnected to (associated) electrical equipment, it is required to perform the "Proof of intrinsic safety" (EN60079-14). Attention! When used in safety systems, all content of the security manual must be observed.
Installation and mounting instructions	Avoid static charging of cables and plastic devices. Please only clean the device with a damp cloth. Do not install the device in a dust flow and avoid build-up of dust deposits on the device. If the devices and the cable could be subject to mechanical damage, they must be protected accordingly. They must also be shielded against strong electro-magnetic fields. The pin configuration and the electrical specifications can be taken from the device marking or the technical data sheet.
Service/Maintenance	Repairs are not possible. The approval expires if the device is repaired or modified by a person other than the manufacturer. The most important data from the approval are listed.