

# BID2-G180-Y0/S212

## Inductive Sensor – For High Pressures

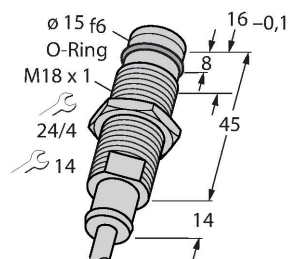

### Features

- Threaded barrel, M18 x 1
- Stainless steel, 1.4305
- Admissible pressure static/dynamic 500/350 bar
- DC 2-wire, nom. 8.2 VDC
- Output acc. to EN 60947-5-6 (NAMUR)
- Cable connection

### Wiring diagram

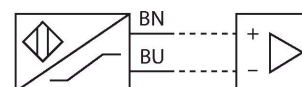

### Technical data

Type	BID2-G180-Y0/S212
ID	1088003
Special version	S212 Corresponds to: new production technology (core and coil encapsulated)
<b>General data</b>	
Rated switching distance	2 mm
Mounting conditions	Flush
Secured operating distance	$\leq (0.81 \times S_n)$ mm
Correction factors	St37 = 1; Al = 0.3; stainless steel = 0.7; Ms = 0.4
Repeat accuracy	$\leq 2$ % of full scale
Static pressure	$\leq 500$ bar
Dynamic pressure	$\leq 350$ bar
Permissible contact medium	electrically non-conductive
Temperature drift	$\leq \pm 10$ %
Hysteresis	1...10 %
<b>Electrical data</b>	
Output function	2-wire, NAMUR
Switching frequency	2 kHz
Voltage	Nom. 8.2 VDC
Non-actuated current consumption	$\geq 2.1$ mA
Actuated current consumption	$\leq 1.2$ mA
<b>Mechanical data</b>	
Design	Threaded barrel, M18 x 1
Dimensions	58 mm
Housing material	Metal, 1.4305 (AISI 303)
Active area material	Plastic, PA12-GF30
Max. tightening torque of housing nut	25 Nm

### Functional principle

Inductive sensors detect metal objects contactless and wear-free. For this purpose they use a high-frequency electromagnetic AC field that interacts with the target. The sensors hosting a ferrite core coil generate the AC field through an LC resonant circuit. Pressure resistant inductive sensors withstand pressures of up to 500 bar which makes them perfectly suited for position control in hydraulic cylinders.

## Technical data

Electrical connection	Cable
Cable quality	Ø 5.2 mm, Blue, LifYY, PVC, 2 m
Core cross-section	2 x 0.34 mm <sup>2</sup>
<b>Environmental conditions</b>	
Ambient temperature	-25...+85 °C
Vibration resistance	55 Hz (1 mm)
Shock resistance	30 g (11 ms)
Protection class	IP67
MTTF	1804 years acc. to SN 29500 (Ed. 99) 40 °C

## Mounting instructions

### Mounting instructions/Description

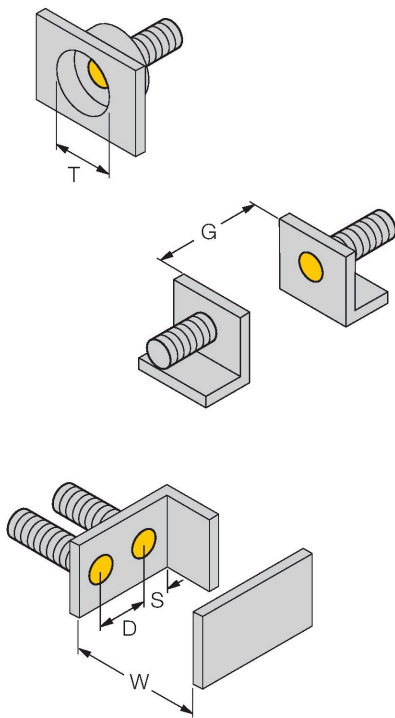

Distance D	2 x B
Distance W	3 x Sn
Distance T	3 x B
Distance S	1.5 x B
Distance G	6 x Sn
Diameter active area B	Ø 18 mm

## Accessories

QM-18

6945102

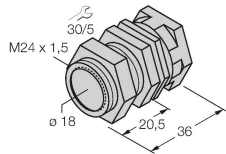

Quick-mount bracket with dead-stop; material: Chrome-plated brass. Male thread M24 × 1.5. Note: The switching distance of the proximity switches may change when using quick-mount brackets.

## Accessories

Dimension drawing	Type	ID	
	IMX12-DI01-2S-2T-0/24VDC	7580020	Isolating switching amplifier, 2-channel; SIL2 acc. to IEC 61508; Ex-proof version; 2 transistor outputs; input Namur signal; ON/OFF switchable monitoring of wire-break and short-circuit; toggle between NO/NC mode; signal doubling; removable screw terminals; 12.5 mm wide; 24 VDC power supply