

# NI30-Q130-VP4X2

## Inductive Sensor

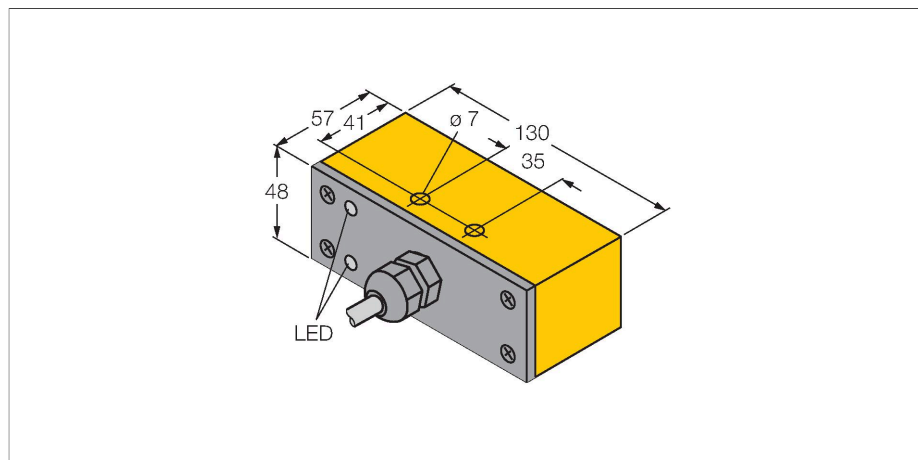

### Features

- Rectangular, height 48 mm
- Active face in front
- Plastic, PBT
- DC 4-wire, 10...65 VDC
- Changeover contact, PNP output
- Cable connection

### Wiring diagram

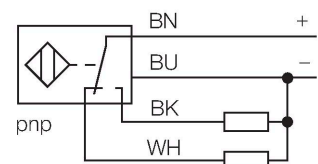

### Functional principle

Inductive sensors detect metal objects contactless and wear-free. For this, they use a high-frequency electromagnetic AC field that interacts with the target. Inductive sensors generate this field via an RLC circuit with a ferrite coil.

### Technical data

Type	NI30-Q130-VP4X2
ID	15179
<b>General data</b>	
Rated switching distance	30 mm
Mounting conditions	Non-flush
Secured operating distance	$\leq (0.81 \times S_n)$ mm
Correction factors	St37 = 1; Al = 0.3; stainless steel = 0.7; Ms = 0.4
Repeat accuracy	$\leq 2$ % of full scale
Temperature drift	$\leq \pm 10$ %
Hysteresis	3...15 %
<b>Electrical data</b>	
Operating voltage $U_B$	10...65 VDC
Ripple $U_{ss}$	$\leq 10$ % $U_{Bmax}$
DC rated operating current $I_o$	$\leq 200$ mA
No-load current	$\leq 15$ mA
Residual current	$\leq 0.1$ mA
Isolation test voltage	0.5 kV
Short-circuit protection	yes/Cyclic
Voltage drop at $I_o$	$\leq 1.8$ V
Wire break/reverse polarity protection	yes/Complete
Output function	4-wire, Complementary contact, PNP
Switching frequency	0.06 kHz
<b>Mechanical data</b>	
Design	Rectangular, Q130
Dimensions	130 x 57 x 48 mm
Housing material	Plastic, PBT

## Technical data

Active area material	Plastic, PBT
Electrical connection	Cable
Cable quality	Ø 5.2 mm, Gray, LifYY, PVC, 2 m
Core cross-section	4 x 0.34 mm <sup>2</sup>
<b>Environmental conditions</b>	
Ambient temperature	-25...+70 °C
Vibration resistance	55 Hz (1 mm)
Shock resistance	30 g (11 ms)
Protection class	IP67
MTTF	2283 years acc. to SN 29500 (Ed. 99) 40 °C
Power-on indication	LED, Green
Switching state	LED, Yellow

## Mounting instructions

### Mounting instructions/Description

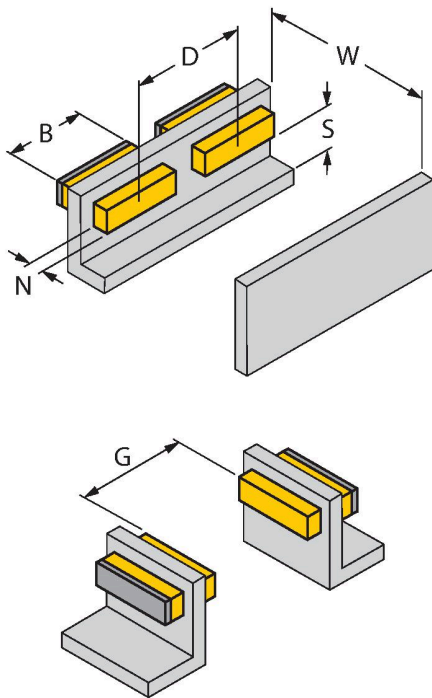

Distance D	180 mm
------------	--------

Distance W	3 x Sn
------------	--------

Distance S	1.5 x B
------------	---------

Distance G	6 x Sn
------------	--------

Distance N	2 x Sn
------------	--------

Width active area	130 mm
B	

Flush mounting of the sensor in metal.