

QS18VN6F W/30

Photoelectric Sensor – Photoelectric Sensor for Glass Fibers

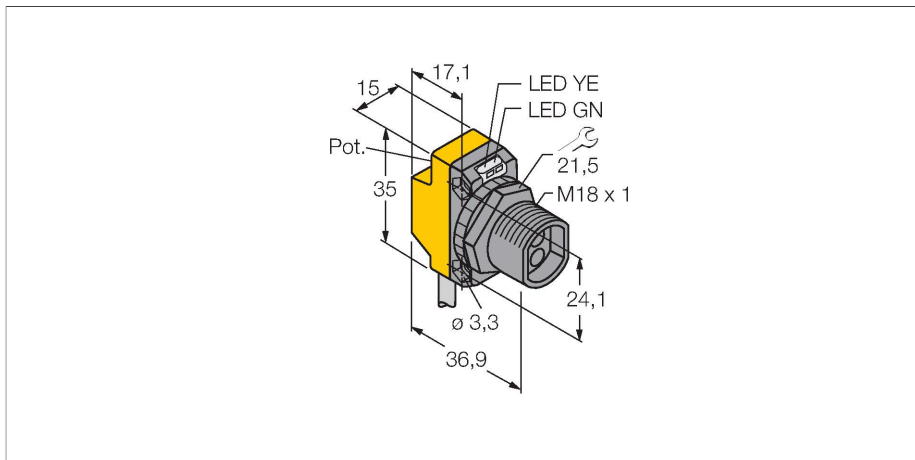

Technical data

Type	QS18VN6F W/30
ID	3002795
Optical data	
Function	Fiber optic sensor
Operating mode	Glass fiber
Fiber-optic type	glass
Light type	IR
Wavelength	940 nm
Electrical data	
Operating voltage	10...30 VDC
Residual ripple	< 10 % U _{ss}
DC rated operational current	≤ 100 mA
Short-circuit protection	yes
Reverse polarity protection	yes
Output function	NO/NC, NPN
Current output	100 mA
Switching frequency	≤ 800 Hz
Readiness delay	≤ 100 ms
Response time typical	< 0.6 ms
Setting option	Potentiometer
Mechanical data	
Design	Rectangular with thread, QS18
Dimensions	36.9 x 15 x 35 mm
Housing material	Plastic, Thermoplastic material
Electrical connection	Cable, 9 m, PVC
Number of cores	4
Core cross-section	0.35 mm ²

Features

- Cable, PVC, 2 m
- Protection class IP67
- LED all-round visible
- Sensitivity adjusted via potentiometer
- Operating voltage: 10...30 VDC
- NPN switching output, changeover

Wiring diagram

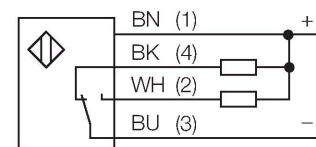

Functional principle

Glass or plastic fibers are the optimum choice for high-temperature applications and narrow spaces. Fiber optics transfer the light from the sensor to a remote object. Individual fibers are used for opposed mode sensing, whereas bifurcated fibers are suited for retroreflective or diffuse mode sensing.

Excess gain curve
Excess gain in relation to the distance for opposed mode sensor (glass fibers IT23S and plastic fibers PIT46U)

Technical data

Ambient temperature	-20...+70 °C
Relative humidity	0...95 %
Protection class	IP67
Special features	Wash down
Power-on indication	LED, Green
Switching state	LED, Yellow
Error indication	LED, green, Flashing
Excess gain indication	LED, yellow, flashing
Tests/approvals	
MTTF	965 years acc. to SN 29500 (Ed. 99) 40 °C
Approvals	CE, cURus

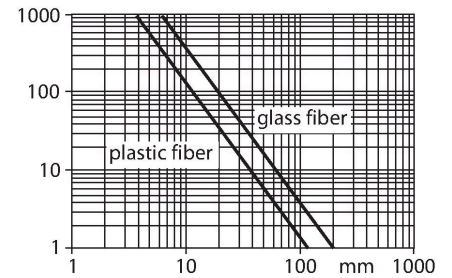

Accessories

SMB18A

3033200

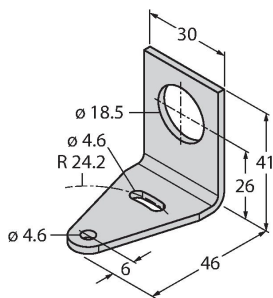

Mounting bracket, rectangular, stainless steel, for sensors with 18 mm thread

SMB18AFAM10

3012558

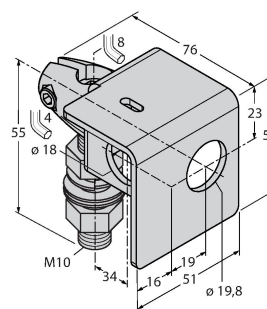

Mounting bracket, material VA 1.4401, for M10 x 1.5 thread, thread length 18 mm

SMBQS18A

3069721

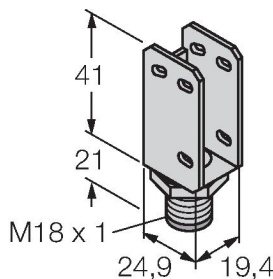

Mounting bracket, stainless steel, for 18 mm thread

SMB18SF

3052519

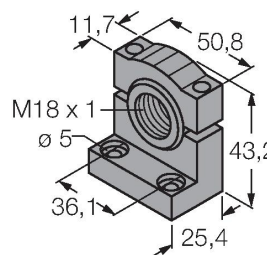

Mounting bracket, PBT black, for sensors with 18 mm thread, rotatable

Accessories

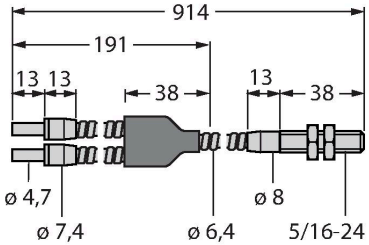
Dimension drawing	Type	ID	
	BT23S	3017276	Glass fiber, sensing mode: Diffuse mode, threaded sleeve (brass), bundle diameter 3.2 mm, flexible stainless steel jacket, ambient temperatures -140...+250 °C

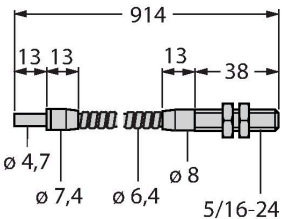
	IT23S	3017355	Glass fiber, sensing mode: Opposed mode, threaded sleeve (brass), bundle diameter 3.2 mm, flexible stainless steel jacket, ambient temperatures -140...+250 °C
--	-------	---------	--