

# Radio Transmission System

## Tree Topology

### Teilnehmer mit RS485-Schnittstelle

### DX80DR2M-H1E

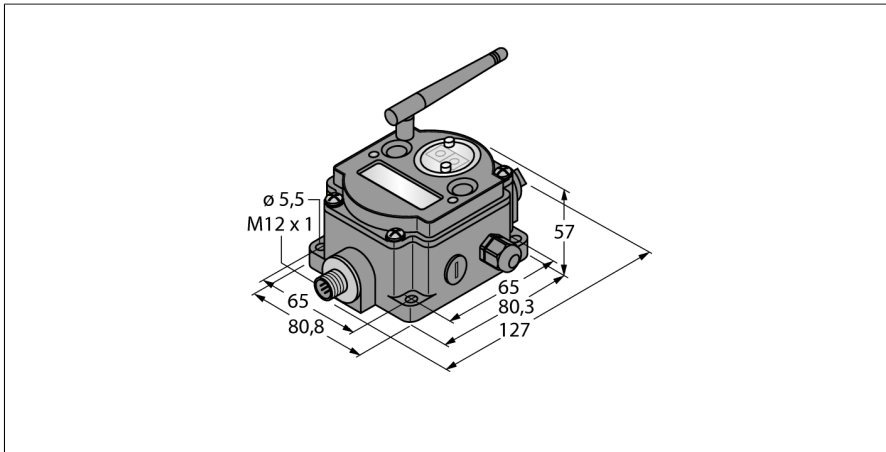

- External antenna (RG58 RP-SMA connection)
- Integrated signal strength indicator
- Configuration via DIP switch
- Modbus RTU (RS485)
- Self-organizing tree structure
- Repeater for extension of network
- Deterministic data transfer
- Frequency hopping FHSS
- Time Division Multiplex Access TDMA
- Transmission power: 63 mW, 18 dBm conducted, ≤ 20 dBm EIRP
- Inputs: 4 x NPN, 2 x 0...20 mA, 1 x thermistor, 1 x counter
- Outputs: 2 x NMOS

Type	DX80DR2M-H1E
ID	3018137

Wireless data	
Type of radio	short-range
Installation	stationary
Topology	Star topology
Function	Tree topology
Device type	Node
Frequency band	2.4-GHz ISM band
Frequency range	2.402 - 2.483 GHz
Number of radio channels	50
Channel width	1 MHz
Spread spectrum technology	FHSS (Frequency Hopping Spread Spectrum)
Single-Carrier Residence Time	7.8 ms
Response time typical	< 1000 ms
Output power ERP	18 dB/65 mW
Output power EIRP	20 dB/100 mW

I/O data	
Number of channels	4 / 2 / 1 / 1
Input type	NPN/0...20 mA/thermistor/counter
Number of channels	2
Output type	NMOS
Communication protocol	Modbus RTU RS485

Electrical data	
runs with battery	ja
Operating voltage	3.6...5.5 VDC
Power-on indication	LED, Green

#### Wiring Diagram

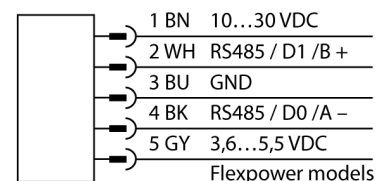

#### Functional principle

The DX80 Data Radios are self-organizing. They create a network in tree topology. They transfer Modbus RTU telegrams or other data from other bus systems. The telegrams are routed through the network and lost radio communication is compensated via alternative routes. Further sensors can be added to the network and their data is accessible via internal registers. Each network consists of a master and an unlimited number of repeaters or slaves. The device type is adjusted via DIP switch. This system can be combined with several DX80 networks to transfer data from the DX80 gateway via Modbus RTU to the control system.

FCC-ID UE300DX80-2400. This device complies with FCC para. 15, subpara. C, 15.247 ETSI/EN: In compliance with EN 300 328: V1.8.1 (2014-04)

IC: 7044A-DX8024

Radiation protection 10 V/m for 80-2700 MHz acc. to EN 61000-6-2

Shock and vibration resistant: IEC 68-2-6 and IEC 68-2-7

Mechanical data	
Design	Rectangular, DX80DR
Housing material	Plastic, PC
Antenna connection	RP-SMA female connector
Ambient temperature	-20...+65 °C
Relative humidity	0...95%
Protection class	IP65
Tests/approvals	
Approvals	ATEX II 3 G
Approvals	CE
	CSA
	ATEX
Device marking	II 3 G Ex nA IIC T4 Gc
Ex approval acc. to conformity certificate	LCIE 10 ATEX 1012 X

## Accessories

Type code	Ident no.		Dimension drawing
SMBDX80DIN	3077161	Mounting panel for DIN rail, suited for CP80, DX80, K80, Q80, operating temperature: -20...90 °C	

## Function accessories

Type code	Ident no.		Dimension drawing
BWA-2O6-A	3081081	External antenna 6 dBi, N-female	
BWA-2O8-A	3081080	External antenna 8.5 dBi, N-female	
BWA-2O2-C	3077816	Internal antenna 2 dBi, RP-SMA male, standard	
BWA-2O5-C	3077817	Internal antenna 5 dBi, RP-SMA male	

**Function accessories**

Type code	Ident no.		Dimension drawing
BWA-207-C	3077818	Internal antenna 7 dBi, RP-SMA male	