

# DF-G1-KS-Q7

## Photoelectric Sensor – Photoelectric Sensor for Plastic Fibers

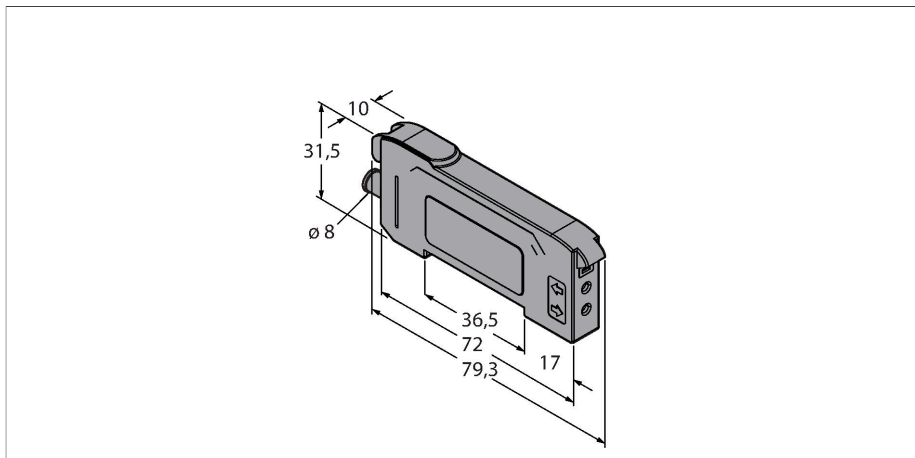

### Technical data

Type	DF-G1-KS-Q7
ID	3025793
<b>Optical data</b>	
Function	Fiber optic sensor
Operating mode	Plastic fiber
Light type	Red
Wavelength	660 nm
<b>Electrical data</b>	
Operating voltage	10...30 VDC
Residual ripple	< 10 % U <sub>ss</sub>
DC rated operational current	≤ 40 mA
Short-circuit protection	yes
Reverse polarity protection	yes
Communication protocol	IO-Link
Output function	NO/NC, PNP
Switching frequency	5 kHz
Readiness delay	≤ 500 ms
Response time typical	< 0.2 ms
Setting option	Push Button
<b>IO-Link</b>	
IO-Link specification	V 1.1
IO-Link port type	Class A
Communication mode	COM 2 (38.4 kBaud)
Process data width	16 bit
Frame type	Type_2_2
Minimum cycle time	2 ms
Function Pin 4	IO-Link

### Features

- 8 mm connector, 4-pin
- Visible red light
- Programming via teach cable or multi-function button
- Operating voltage: 10...30 VDC
- IO-Link
- 2 × PNP output, changeover contact
- Light/dark operation

### Wiring diagram

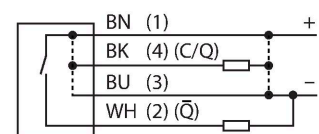

### Functional principle

Glass or fiber optics are the optimum choice for high temperature or space restricted applications. Fiber optics transfer the light from the sensor to a remote object. Individual fiber optics are used for opposed mode sensing, whereas bifurcated fiber optics are suited for diffuse mode operation.

## Technical data

Function Pin 2	DI
Maximum cable length	20 m
Profile support	Smart Sensor Profil
Included in the SIDI GSDML	Yes
<b>Mechanical data</b>	
Design	Rectangular, DF-G1
Dimensions	79.3 x 10 x 33 mm
Housing material	Plastic, Thermoplastic material, Black
Electrical connection	Connector, M8 × 1, PVC
Number of cores	4
Ambient temperature	-10...+55 °C
Relative humidity	0...90 %
Protection class	IP50
Special features	keep/defer
Switching state	LED, Yellow
Excess gain indication	Dual Digital Displays
<b>Tests/approvals</b>	
Approvals	CE, cULus listed

## Excess Gain Curve

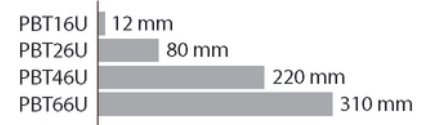
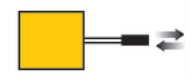
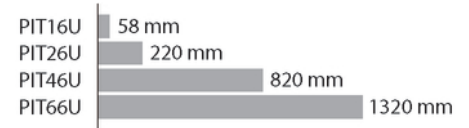
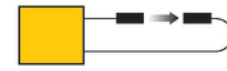

## Accessories

DIN-35-70	3026604	DIN-35-105	3030470
	DIN rail, width 35 mm, length 70 mm		DIN rail, width 35 mm, length 105 mm
DIN-35-140	3026605		
	DIN rail, width 35 mm, length 140 mm		

## Accessories

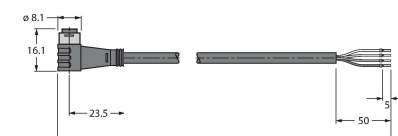
Dimension drawing	Type	ID	
	PKG4S-2/TEL	6627370	Connection cable, female Ø M8, straight, 4-pin, snap-on type, cable length: 2 m, jacket material: PVC, black; cULus approval; other cable lengths and qualities available, see <a href="http://www.turck.com">www.turck.com</a>
	PKW4S-2/TEL	6627373	Connection cable, Ø 8 mm female, snap-on type, angled, 4-pin, cable length: 2 m, jacket material: PVC, black; cULus approval; other cable lengths and qualities available, see <a href="http://www.turck.com">www.turck.com</a>

Accessories

Dimension drawing	Type	ID	
	BL67-4IOL	6827386	4-channel IO-Link Master module for the modular BL67 I/O-system
	BL20-E-4IOL	6827385	IO-Link master module for the modular BL20 I/O system, 4-channel
	USB-2-IOL-0002	6825482	IO-Link Master with integrated USB port
	TBIL-M1-16DXP	6814102	16-channel I/O-hub for the connection of 16 digital PNP signals to an IO-Link master (input/output freely selectable per channel)

Dimension drawing

Type

ID

TBEN-S2-4IOL

6814024

Compact multiprotocol I/O module, 4 IO-Link Master 1.1 Class A, 4 universal PNP digital channels 0.5 A

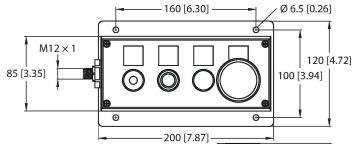
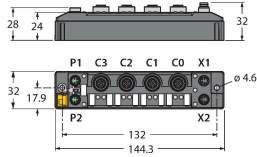

OPIL-E4-I02-FE01(DE)

100029326

16-channel I/O hub for the connection of 16 digital PNP signals to an IO-Link master (input/output freely selectable per channel)



mm [inch]

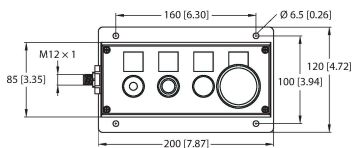

OPIL-E4-I02-FE02

100029327

16-channel I/O hub for the connection of 16 digital PNP signals to an IO-Link master (input/output freely selectable per channel)

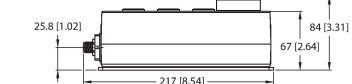

mm [inch]

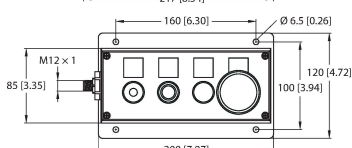

OPIL-E4-I02-FE03

100029328

16-channel I/O hub for the connection of 16 digital PNP signals to an IO-Link master (input/output freely selectable per channel)



mm [inch]

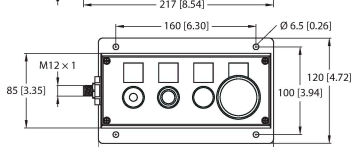

OPIL-E4-I03-FE04

100036394

16-channel I/O hub for the connection of 16 digital PNP signals to an IO-Link master (input/output freely selectable per channel)



mm [inch]

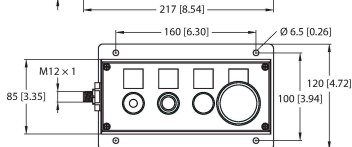

OPIL-E4-I03-FE01

100036505

16-channel I/O hub for the connection of 16 digital PNP signals to an IO-Link master (input/output freely selectable per channel)

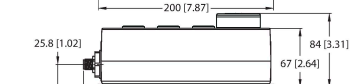

mm [inch]

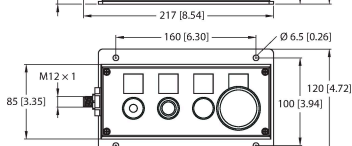

OPIL-E4-I03-FE02

100036506

16-channel I/O hub for the connection of 16 digital PNP signals to an IO-Link master (input/output freely selectable per channel)

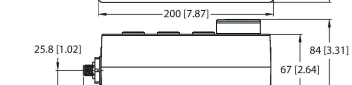

mm [inch]

## Dimension drawing

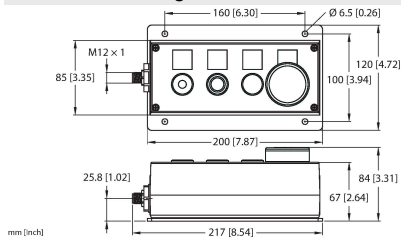

## Type

OPIL-E4-IO3-FE03

## ID

100036507

16-channel I/O hub for the connection of 16 digital PNP signals to an IO-Link master (input/output freely selectable per channel)

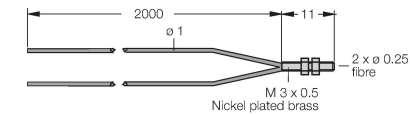

PBT16U

3042822

Plastic fiber-optic sensor, operating mode: Diffuse mode, threaded sleeve M3 x 0.75 mm, field wireable wire without end tip, polyethylene sheath, ambient temperatures -30 °C...+70 °C

PBT26U

3026080

Plastic fiber, sensing mode: Diffuse mode, threaded bush M3 x 0.75 mm, preassembled wire without end tip, polyethylene jacket, ambient temperatures -30 °C...+70 °C

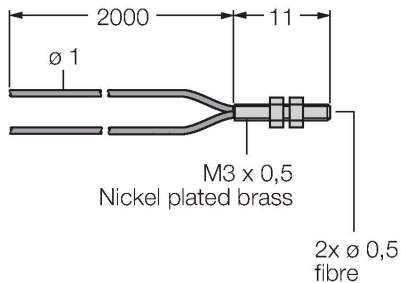

PBT46U

3025967

Plastic fiber-optic sensor, operating mode: Diffuse mode, threaded sleeve M3 x 0.75 mm, field wireable wire without end tip, polyethylene sheath, ambient temperatures -30 °C...+70 °C

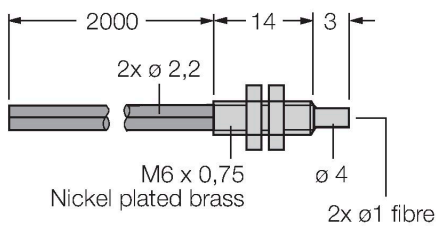

Dimension drawing	Type	ID	
	PBT66U	3039982	Plastic fiber-optic sensor, operating mode: Diffuse mode, threaded sleeve M6 x 0.75 mm, pre-assembled wire without end tip, polyethylene sheath, ambient temperatures -30 °C...+70 °C

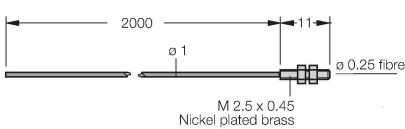
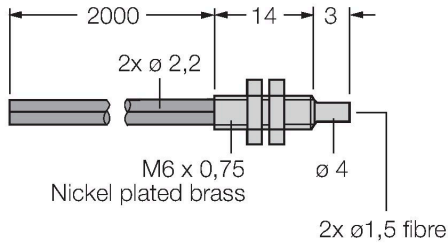

PIT16U	3039983	Plastic fiber-optic sensor, operating mode: Opposed mode, threaded sleeve M3 x 0.5 mm, field wireable wire without end tip, polyethylene sheath, ambient temperatures -30 °C...+70 °C
--------	---------	---

PIT26U	3026079	Plastic fiber, sensing mode: Opposed mode, threaded bush M3 x 0.5 mm, preassembled wire without end tip, polyethylene jacket, ambient temperatures -30 °C...+70 °C
--------	---------	--

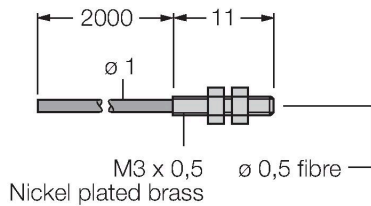

PIT46U	3026034	Plastic fiber-optic sensor, operating mode: Opposed mode, threaded sleeve M3 x 0.5 mm, field wireable wire without end tip, polyethylene sheath, ambient temperatures -30 °C...+70 °C
--------	---------	---

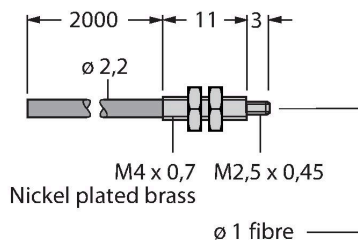

Dimension drawing	Type	ID	
	PIT66U	3039899	Plastic fiber-optic sensor, operating mode: Opposed mode, threaded sleeve M3 x 0.5 mm, field wireable wire without end tip, polyethylene sheath, ambient temperatures -30 °C...+70 °C

