

# Temperature and Humidity Sensor With Serial Interface RS485/Modbus RTU M12FTH3Q

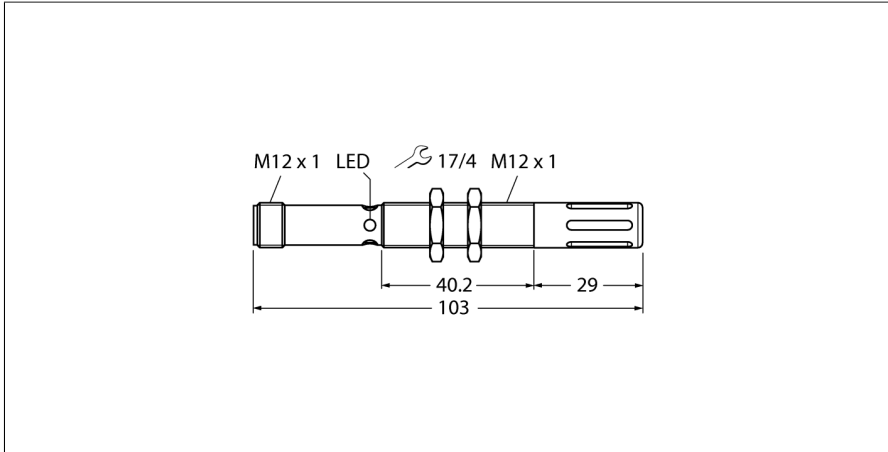

Type	M12FTH3Q
ID	3025898
<b>Wireless data</b>	
Function	Temperature/humidity sensor
Device type	Sensor
<b>I/O data</b>	
Communication protocol	Modbus RTU RS485
<b>Electrical data</b>	
Operating voltage	12...24 VDC
<b>Mechanical data</b>	
Design	Tube, M12FTH
Housing material	Metal, Grey
Electrical connection	Connector, M12 × 1
Antenna connection	No radio participant
Ambient temperature	-40...+85 °C
Relative humidity	0...100%
Protection class	IP67
<b>Tests/approvals</b>	

- Robust metal housing
- Ambient temperature: -40...+85 °C
- Protection class IP67
- Relative humidity: 0...100 %
- Resolution: 0.1 %
- Temperature measuring range: -40...+85 °C
- Resolution: 0.1 °C
- Operating voltage: 10...24 VDC or 3.6...5.5 VDC
- RS485 interface, supports Modbus RTU

### Wiring Diagram

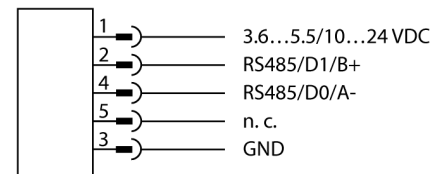

### Functional principle

This sturdy sensor in a metal housing was developed to monitor vibrations and the temperature of moving machine parts. The data can be transferred to a controller via the RS485 interface, allowing an imminent failure of the machine to be detected at an early stage and corrective action to be taken. The rugged housing is IP67-rated and allows the detection of vibrations on two axes. The sensor can be mounted or stuck on the machine with the relevant accessories.

## Function accessories

Type code	Ident no.		Dimension drawing
BWA-HW-006	3081325	<p>Converter cable, RS485 to USB 2.0 converter, female connector, M12 × 1, 5-pin, male connector, USB type A, length 1 m; supplies the connected device with 10 V. An external power supply via a Y-splitter (6634679) is recommended for the connected device</p>	