

# Q45VR3F W/30

## Photoelectric Sensor – Photoelectric Sensor for Glass Fibers

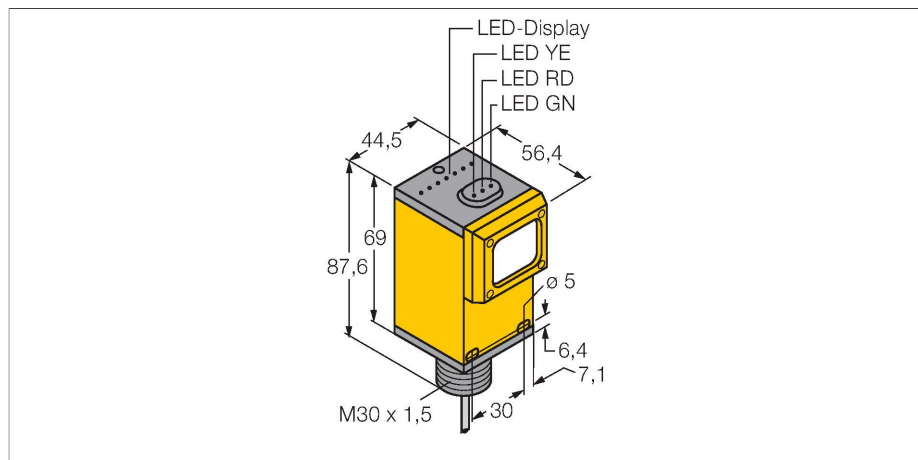

### Technical data

Type	Q45VR3F W/30
ID	3063154
<b>Optical data</b>	
Function	Fiber optic sensor
Operating mode	Glass fiber
Fiber-optic type	glass
Light type	IR
Wavelength	880 nm
<b>Electrical data</b>	
Operating voltage	12...250 VDC
Operating voltage	24...250 VAC
Output function	Complementary contact, Relay output
Switching frequency	≤ 33 Hz
Readiness delay	≤ 100 ms
Response time typical	< 15 ms
Setting option	Potentiometer
<b>Mechanical data</b>	
Design	Rectangular, Q45
Dimensions	56.4 x 44.5 x 87.6 mm
Housing material	Plastic, Thermoplastic material
Lens	plastic, Acrylic
Electrical connection	Cable, 9 m, PVC
Number of cores	5
Core cross-section	0.34 mm <sup>2</sup>
Ambient temperature	-25...+55 °C
Relative humidity	0...90 %
Protection class	IP67

### Features

- Cable, PVC, 2 m
- Protection class IP67
- Sensitivity adjusted via potentiometer
- Operating voltage: 12...250 VDC or 24...250 VAC
- Relay output, changeover (SPDT)
- Light or dark operation, adjusted via selector switch

### Wiring diagram

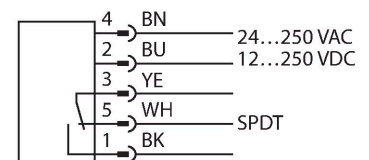

### Functional principle

Glass or fibre optic sensors are the optimum choice for high temperature or space restricted applications. Fibre optics transfer the light from the sensor to a remote object. Individual fibre optics are used for opposed mode sensing, whereas bifurcated fibre optics are suited for retro-reflective or diffuse mode operation.

Excess gain curve  
Excess gain in relation to the distance

## Technical data

Special features	keep/defer Wash down
Power-on indication	LED, Green
Switching state	LED, Yellow
Error indication	LED, green
Excess gain indication	LED, red
<b>Tests/approvals</b>	
MTTF	67 years acc. to SN 29500 (Ed. 99) 40 °C
Approvals	CE, cURus, CSA

## Accessories

**SMB30A** 3032723

Mounting bracket, rectangular, stainless steel, for sensors with 30mm thread

**SMB30FAM10** 3011185

Mounting bracket, stainless steel, for M10 x 1.5 thread, thread length 30 mm

**SMB30SC** 3052521

Mounting bracket, PBT black, for sensors with 30 mm thread, rotatable

## Accessories

Dimension drawing	Type	ID	
	IT23S	3017355	Glass fiber, sensing mode: Opposed mode, threaded sleeve (brass), bundle diameter 3.2 mm, flexible stainless steel jacket, ambient temperatures -140... +250 °C

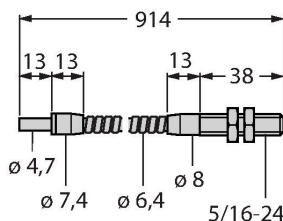

Dimension drawing	Type	ID	
	BT23S	3017276	Glass fiber, sensing mode: Diffuse mode, threaded sleeve (brass), bundle diameter 3.2 mm, flexible stainless steel jacket, ambient temperatures -140...+250 °C

