

# QS18VP6FPQ7

## Photoelectric Sensor – Photoelectric Sensor for Plastic Fibers

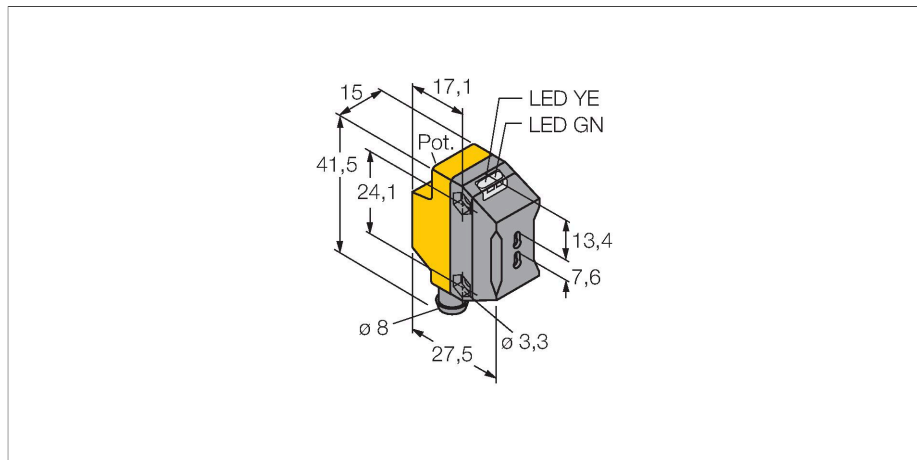

### Technical data

Type	QS18VP6FPQ7
ID	3066446
<b>Optical data</b>	
Function	Fiber optic sensor
Operating mode	Plastic fiber
Fiber-optic type	plastic
Light type	Red
Wavelength	660 nm
<b>Electrical data</b>	
Operating voltage	10...30 VDC
Residual ripple	< 10 % U <sub>ss</sub>
DC rated operational current	≤ 100 mA
Short-circuit protection	yes
Reverse polarity protection	yes
Output function	NO/NC, PNP
Current output	100 mA
Switching frequency	≤ 800 Hz
Readiness delay	≤ 100 ms
Response time typical	< 0.6 ms
Setting option	Potentiometer
<b>Mechanical data</b>	
Design	Rectangular, QS18
Dimensions	Ø 18 x 27.5 x 15 x 41.5 mm
Housing material	Plastic, ABS
Lens	Acrylic
Electrical connection	Connector, M8 × 1, PVC
Number of cores	4

### Features

- Male connector, M8 × 1, 4-pin
- Protection class IP67
- LED all-round visible
- Sensitivity adjusted via potentiometer
- Operating voltage: 10...30 VDC
- PNP switching output, changeover

### Wiring diagram

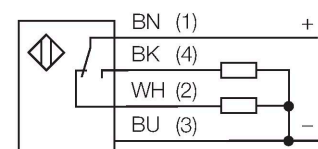

### Functional principle

Glass or plastic fibers are the optimum choice for high-temperature applications and narrow spaces. Fiber optics transfer the light from the sensor to a remote object. Individual fibers are used for opposed mode sensing, whereas bifurcated fibers are suited for retroreflective or diffuse mode sensing.

Excess gain curve  
Excess gain in relation to the distance for opposed mode sensor (glass fibers IT23S and plastic fibers PIT46U)

## Technical data

Ambient temperature	-20...+70 °C
Protection class	IP67
Power-on indication	LED, Green
Switching state	LED, Yellow
Error indication	LED, green, Flashing
Excess gain indication	LED, yellow, flashing
<b>Tests/approvals</b>	
MTTF	965 years acc. to SN 29500 (Ed. 99) 40 °C
Approvals	CE, cURus

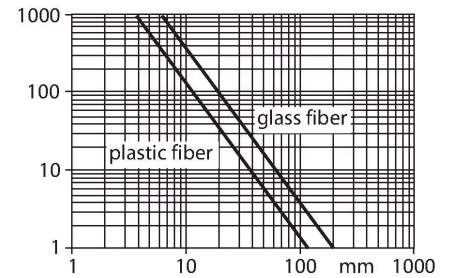

## Accessories

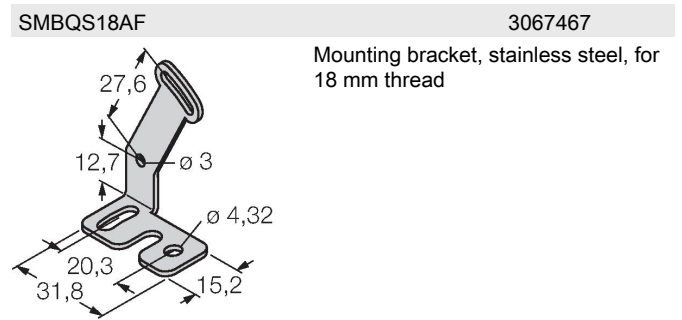
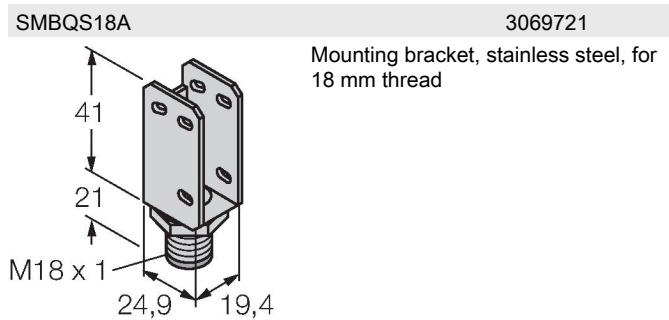

## Accessories

Dimension drawing	Type	ID	
	PKG4M-2/TEL	6625061	Connection cable, female M8, straight, 4-pin, cable length: 2 m, sheath material: PVC, black; cULus approval; other cable lengths and qualities available, see <a href="http://www.turck.com">www.turck.com</a>
	PKW4M-2/TEL	6625067	Connection cable, female M8, angled, 4-pin, cable length: 2 m, sheath material: PVC, black; cULus approval; other cable lengths and qualities available, see <a href="http://www.turck.com">www.turck.com</a>

Accessories

Dimension drawing	Type	ID	
	PBT46U	3025967	Plastic fiber-optic sensor, operating mode: Diffuse mode, threaded sleeve M3 x 0.75 mm, field wireable wire without end tip, polyethylene sheath, ambient temperatures -30 °C...+70 °C

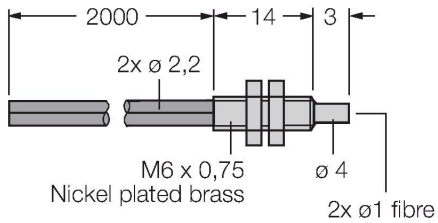

PIT46U	3026034
--------	---------

Plastic fiber-optic sensor, operating mode: Opposed mode, threaded sleeve M3 x 0.5 mm, field wireable wire without end tip, polyethylene sheath, ambient temperatures -30 °C...+70 °C

