

M18TB6E

Temperature sensor – Infrared sensor

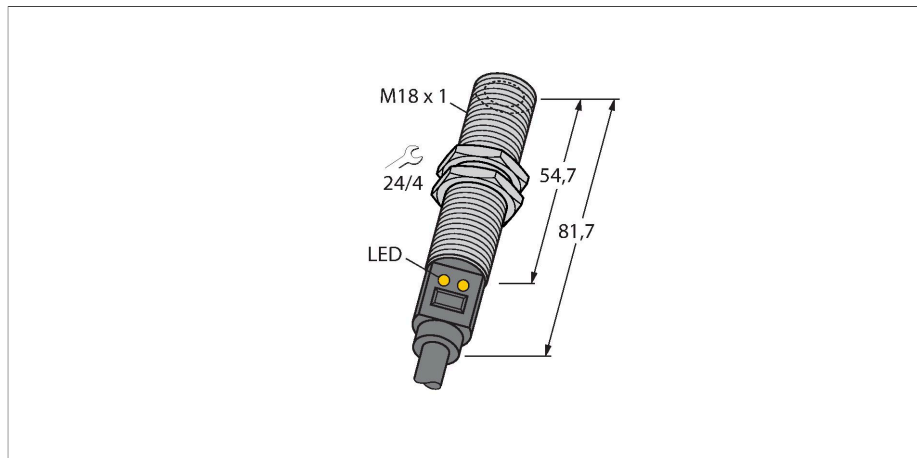

Features

- Connection via cable, 2 m
- D:S ratio 6:1
- Operating voltage 10...30 VDC
- Switchpoint adjustable via teach-in
- Temperature range 0...300°C

Wiring diagram

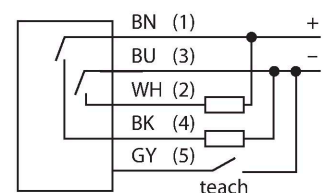

Functional principle

Temperature sensors are used in applications where temperatures for control and optimisation of processes must be captured and monitored. The sensor operates only as a receiver. The thermal radiation of an object within a wave length range of 8 to 14 μm is transformed into an electrical signal via a thermopile and then further processed to become an output signal. Here the D:S (distance: spot) ratio is very important because it specifies the diameter of the spot at a defined distance. The sensor is optimally aligned, if the spot is completely covered by the object, whose temperature is to be monitored.

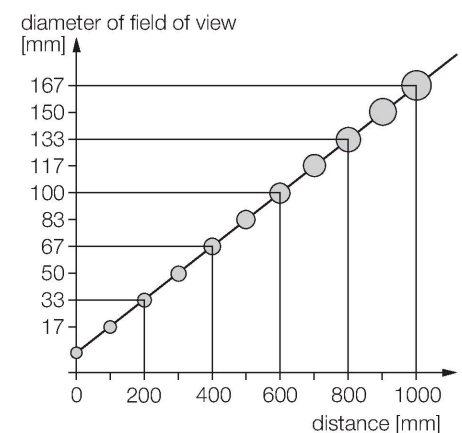

Technical data

Type	M18TB6E
ID no.	3073648
Measuring range	0...300 °C
Temperature operating range	-4...158 °F
Factory setting	-20...280 °C
	-4...536 °F
Response time	25 ms
Operating voltage	10...30 VDC
Short-circuit/reverse polarity protection	yes / Cyclic / yes
Protection type and class	IP67
Output 1	Switching output
Switching output	
Output function	NO contact, PNP/NPN
Switching current	≤ 100 mA
Switching frequency	≤ 20 Hz
Response time typical	< 25 ms
Ambient temperature	-20...+70 °C
Storage temperature	-20...+70 °C
Housing	
Housing material	Stainless steel, 1.4301 (AISI 304), Grey
Process connection	M18 × 1
Electrical connection	Cable
Cable quality	Ø 6 mm, Black, PVC, 2 m, 2 m
Core cross-section	5 x 0.5 mm ²
Switching state	LED, Yellow
Included in delivery	2 M18 × 1 metal hexagon nuts

Accessories

SMB18A **3033200**

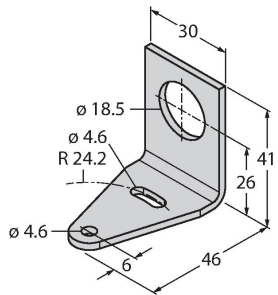

Mounting bracket, rectangular, stainless steel, for sensors with 18 mm thread

SMB18SF **3052519**

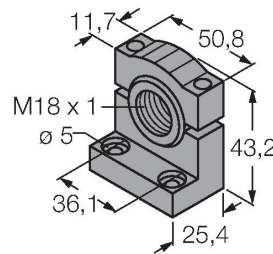

Mounting bracket, PBT black, for sensors with 18 mm thread, rotatable

SMB18UR **3052517**

Mounting bracket, for wall mounting, stainless steel 300, 2-piece, rotatable, 18 mm bore hole, screw set included

LAT1812 **3074262**

Laser alignment aid, visible red, contains M12 laser emitter (laser class 2) and mounting bracket SMB1812, for sensors with 18 mm thread, 10 ... 30 VDC supply necessary