

# R58ECR2GB2Q

## Photoelectric Sensor – Convergent Mode Sensor

### Color Mark Sensor

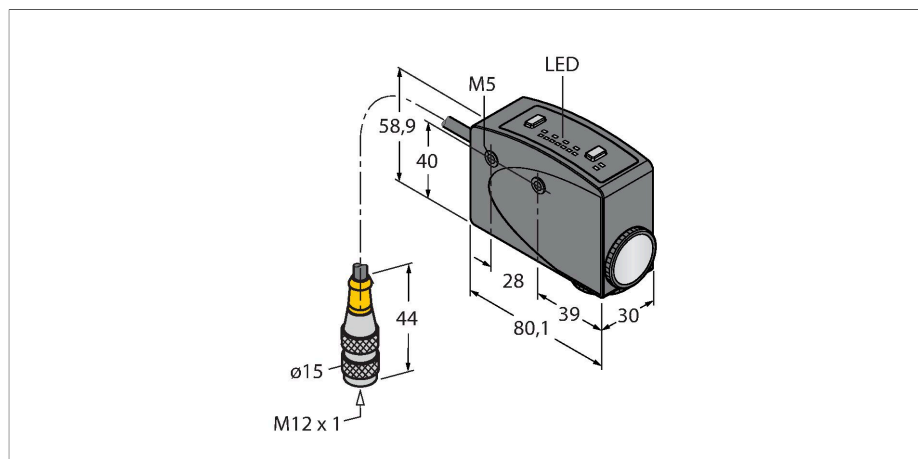

### Features

- Cable with male end, PVC, 5-pin, 150 mm
- Protection class IP67
- Programmed via 2 teach buttons
- 8-segment LED display
- Adjustable on/off delay, 30 ms
- Automatic selection of red, green and blue light
- Orthogonal scan field relative to longitudinal housing axis
- Optics rotatable by 90°
- Operating voltage: 10...30 VDC
- PNP/NPN switching output
- Switching behavior adjustable (NO/NC)
- Teach input

### Technical data

Type	R58ECR2GB2Q
ID	3075044
<b>Optical data</b>	
Function	Inspection sensor
Operating mode	Contrast sensor
Light type	RGB
Focal distance	10 mm
Range	10 mm
<b>Electrical data</b>	
Operating voltage	10...30 VDC
Residual ripple	< 10 % U <sub>ss</sub>
DC rated operational current	≤ 100 mA
No-load current	≤ 75 mA
Short-circuit protection	yes
Reverse polarity protection	yes
Output function	NO contact, PNP/NPN
Switching frequency	10 kHz
Readiness delay	≤ 1000 ms
Setting option	Push Button Remote Teach
<b>Mechanical data</b>	
Design	Rectangular, R58
Dimensions	80.1 x 30 x 58.9 mm
Housing material	Metal, Zinc Alloy Die-Cast, Black-finished
Lens	plastic, Acrylic

### Wiring diagram

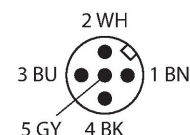
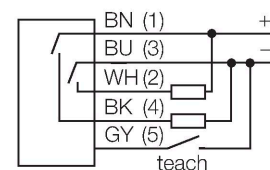

### Functional principle

The color mark sensor differentiates between all conventional color contrasts occurring in product and material registration. From three differently colored LEDs, the device automatically selects the most appropriate one to achieve the highest contrast ratio. The very short response time of 50 μs is ideally suited for high speed applications. Adjustments such as contrast ratio, switch behaviour and time delay, can either be made directly via pushbuttons at the sensor or remotely via external teach line (gy). Furthermore, the device can be taught to differentiate between ON and OFF state, either statically before commissioning or dynamically during operation.



Dimension drawing	Type	ID	
	RKC4.5T-2/TEL	6625016	Connection cable, female M12, straight, 5-pin, cable length: 2 m, sheath material: PVC, black; cULus approval; other cable lengths and qualities available, see <a href="http://www.turck.com">www.turck.com</a>