

S22AMTSRGB7

Pick-to-Light – Placement Sensor

Capacitive Sensor

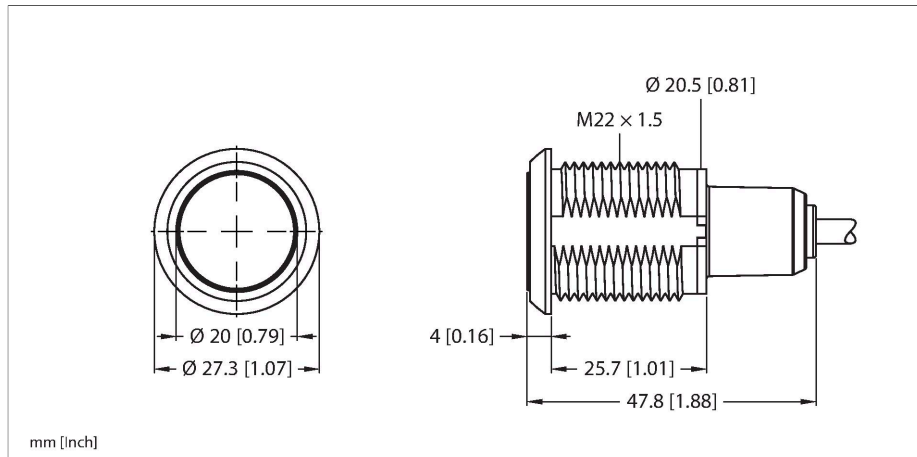

Features

- Protection class IP67/IP69K
- 2m cable
- RGB-LEDS
- Can display up to seven colors
- Operating voltage 10...30 VDC
- Bipolar circuit
- NO contact

Wiring diagram

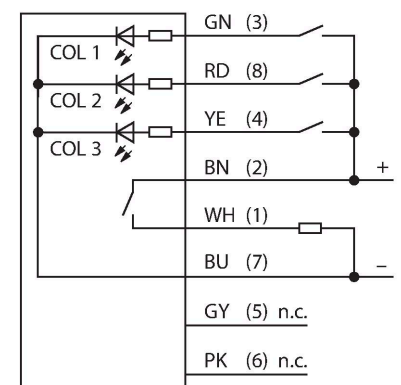

Functional principle

The S22 pick-and-place sensor is suitable for many mounting and component placement applications. The device has RGB LEDs and, depending on the version, between one and seven display colors that are activated depending on the input. The display colors for each input can be individually configured using the Pro Editor software. It is also possible to configure the pick-and-place sensor as NO or NC, with or without holding function. The major advantage of these LEDs is the color fidelity and luminance. Compared to their predecessors, a large number of

Technical data

Type	S22AMTSRGB7
ID	3804250
Signal and display data	
Purpose	Pick-to-Light
Function	Touch Button
Light type	RGB
LED service life (L70)	50000 h
Switch Function	Momentary
Features of color 1	Red, Permanently on, 0.08 lm
Features of color 2	Green, 0.18 lm
Features of color 3	Blue, 0.03 lm
Features of color 4	Yellow, 0.25 lm
Features of color 5	White, 0.24 lm
Features of color 6	Magenta, 0.1 lm
Features of color 7	Magenta, 0.2 lm
Special features	Wash down Wash down
Electrical data	
Max. current consumption per color	80 mA
Output function	NO contact, PNP/NPN
Input type	Bipolar (PNP/NPN)
Response time typical	< 300 ms
Mechanical data	
Design	Threaded barrel
Dimensions	$\varnothing 27.3 \times 47.8$ mm
Housing material	Plastic, PC, Black

Technical data

Window material	Polycarbonate, diffuse
Electrical connection	Cable, 2 m, PVC
Number of cores	8
Ambient temperature	-40...+50 °C
Relative humidity	0...90 %
Protection class	IP66 IP67 IP69

Tests/approvals

variants can be produced with just a single light.

Excess Gain Curve

	R	Y	G	T	B	M	W
COL1	x	x				x	x
COL2		x	x	x			x
COL3				x	x	x	x