

# BI3-M08E-VP6X-V1141

## Inductive Sensor – With Increased Switching Distance

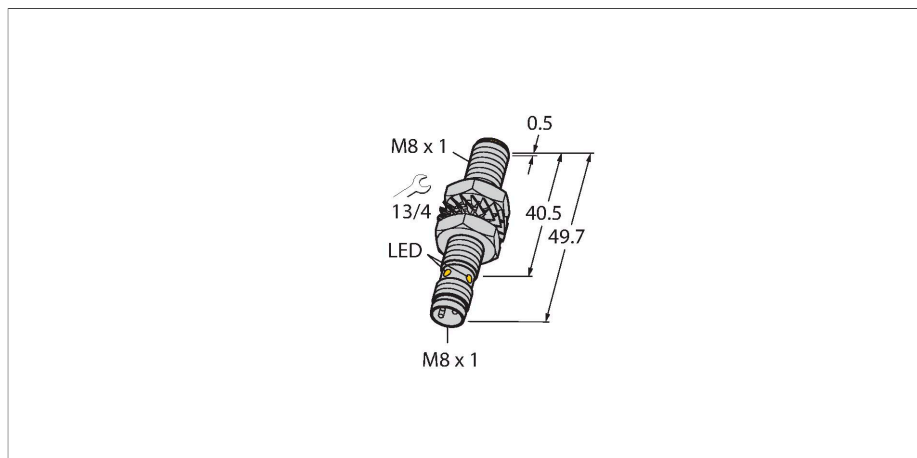

### Features

- Threaded barrel, M8 x 1
- Nickel-plated brass
- Large sensing range
- DC 4-wire, 10...30 VDC
- Changeover contact, PNP output
- M8 x 1 male connector

### Wiring diagram

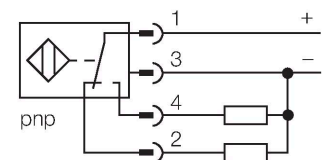

### Functional principle

Inductive sensors detect metal objects contactless and wear-free. For this, they use a high-frequency electromagnetic AC field that interacts with the target. Inductive sensors generate this field via an RLC circuit with a ferrite coil.

### Technical data

Type	BI3-M08E-VP6X-V1141
ID	4602818
<b>General data</b>	
Rated switching distance	3 mm
Mounting conditions	Flush
Secured operating distance	$\leq (0.81 \times S_n)$ mm
Correction factors	St37 = 1; Al = 0.3; stainless steel = 0.7; Ms = 0.4
Repeat accuracy	$\leq 2$ % of full scale
Temperature drift	$\leq \pm 10$ %
Hysteresis	3...15 %
<b>Electrical data</b>	
Operating voltage $U_B$	10...30 VDC
Ripple $U_{ss}$	$\leq 10$ % $U_{Bmax}$
DC rated operating current $I_o$	$\leq 150$ mA
No-load current	$\leq 15$ mA
Residual current	$\leq 0.1$ mA
Isolation test voltage	0.5 kV
Short-circuit protection	yes/Cyclic
Voltage drop at $I_o$	$\leq 1.8$ V
Wire break/reverse polarity protection	yes/Complete
Output function	4-wire, Complementary contact, PNP
Switching frequency	2.8 kHz
<b>Mechanical data</b>	
Design	Threaded barrel, M8 x 1
Dimensions	49.7 mm
Housing material	Metal, CuZn, Nickel Plated

## Technical data

Active area material	Plastic, PP-GF20
Max. tightening torque of housing nut	7 Nm
Electrical connection	Connector, M8 × 1
<b>Environmental conditions</b>	
Ambient temperature	-25...+70 °C
Vibration resistance	55 Hz (1 mm)
Shock resistance	30 g (11 ms)
Protection class	IP67
MTTF	2283 years acc. to SN 29500 (Ed. 99) 40 °C
Switching state	LED, Yellow

## Mounting instructions

### Mounting instructions/Description

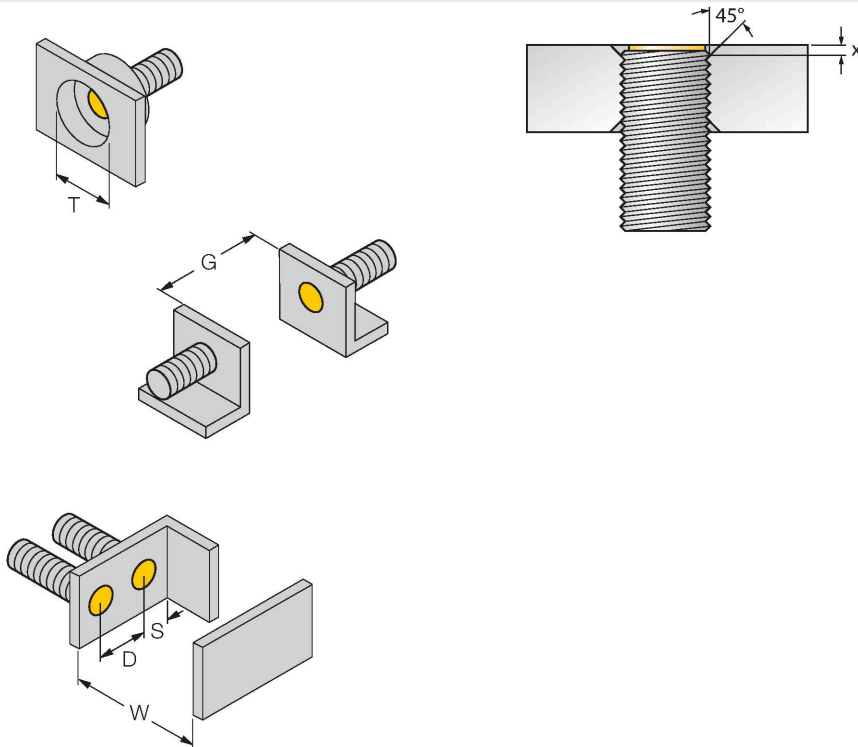

Distance D	2 x B
Distance W	3 x Sn
Distance T	3 x B
Distance S	1.5 x B
Distance G	6 x Sn
Diameter active area B	Ø 8 mm

Flush installation in brass, aluminium and stainless steel with the supplied nuts is possible without restrictions. If installed flush in steel, a phase of 45° and min. depth of 1.7 mm (dimension X) must be observed.

## Accessories

MW08

6945008

Mounting bracket for threaded barrel sensors; material: Stainless steel A2 1.4301 (AISI 304)



BSS-08

6901322

Mounting clamp for smooth and threaded barrel sensors; material: Polypropylene



MBS80

69479

Mounting clamp for smooth barrel sensors; mounting block material: Anodized aluminum

