

# Accessories

## Screw-In Adapter

### For Flow Sensors F(T)CST

#### FCA-FCST-G1/2-A4/L037

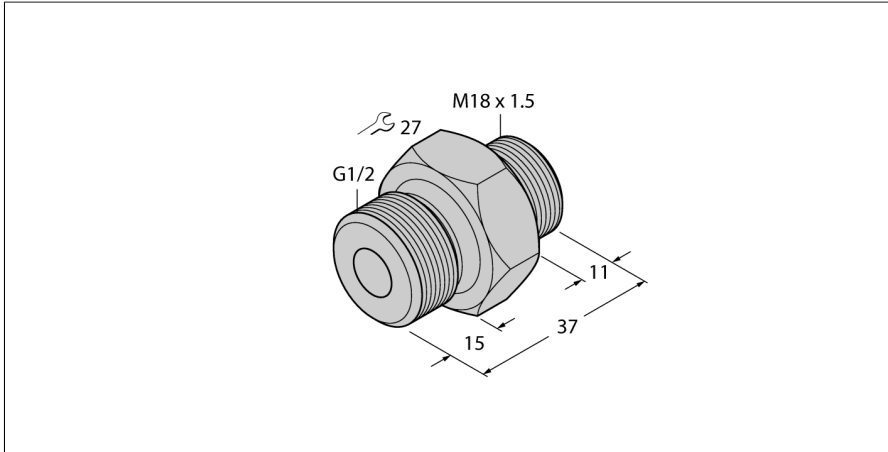

- Screw-in adapter for sensors of the F(T)CST series
- For a T-splitter or a welding sleeve
- Connection seals reliably up to 100 bar
- Process connection G1/2" male thread

#### Functional principle

Thanks to the modular plug-in concept, the F(T)CST sensor can be aligned freely within the flow channel, independent from the process connection.

For this, the adapter is screwed in a T-piece or a weld-on sleeve. Then, the sensor is plugged and fixed in the adapter.

The adapters are available in all standard industrial thread sizes. The sensor-adapter system can thus be adjusted easily to any application requirements.

ID	6870292
Type	FCA-FCST-G1/2-A4/L037
Sensor material	Stainless steel, 1.4571 (AISI 316Ti)
Process connection	G 1/2" male thread