

FCS-G1/2A4-NAEX-H1141

Flow Monitoring – Immersion Sensor without Integrated Processor

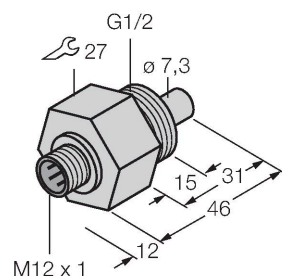

Features

- Ex sensor for liquid media
- Calorimetric functionality
- Adjustment via Ex signal processor
- Status displayed via signal processor
- Intrinsically safe Ex ib IIC T6...T3, for use in Zone 1
- Connector device
- 4-wire connection to an Ex signal processor
- ATEX category II 2 G, Ex zone 1
- ATEX category II 2 D, Ex zone 21

Wiring diagram

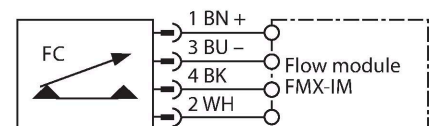

Functional principle

Our insertion - flow sensors operate on the principle of thermodynamics. The measuring probe is heated by several °C as against the flow medium. When fluid moves along the probe, the heat generated in the probe is dissipated. The resulting temperature is measured and compared to the medium temperature. The flow status of every medium can be derived from the evaluated temperature difference. Thus TURCK's wear-free flow sensors reliably monitor the flow of gaseous and liquid media.

Technical data

ID	6870322
Type	FCS-G1/2A4-NAEX-H1141
Mounting conditions	Immersion sensor
Water Operating Range	1...100 cm/s
Oil Operating Range	3...200 cm/s
Minimum immersion depth	≥ 15 mm
Stand-by time	typ. 8 s (2...18 s)
Switch-on time	typ. 2 s (1...13 s)
Switch-off time	typ. 2 s (1...13 s)
Temperature jump, response time	max. 12 s
Temperature gradient	≤ 250 K/min
Medium temperature	-20...+85 °C
Electrical data	
Important note	For Ex applications, the values specified in the corresponding Ex certificates (ATEX, IECEx, UL, etc.) apply.
Device marking	Ex II 2 G Ex ib IIC T6...T3 Gb Ⓔ II 2 D Ex ib IIIC T125 °C Db
Ignition protection category	Gas Ex ib IIC; dust Ex ib IIIC
Power	≤ 0.69 W
Internal capacitance (C _i)/inductance (L _i)	0.45 nF/1.80 μH
Ex approval acc. to conformity certificate	TÜV 99 ATEX 1518
Protection class	IP67
Mechanical data	
Design	Immersion
Housing material	Stainless steel, 1.4571 (AISI 316Ti)
Sensor material	Stainless steel, 1.4571 (AISI 316Ti)

Technical data

Max. tightening torque of housing nut	30 Nm
Electrical connection	Connector, M12 × 1
Pressure resistance	60 bar
Process connection	G 1/2"
Included in delivery	2 × AFM 34 G1/2 flat seal
Tests/approvals	
Approvals	ATEX CE UKCA GOST

Accessories

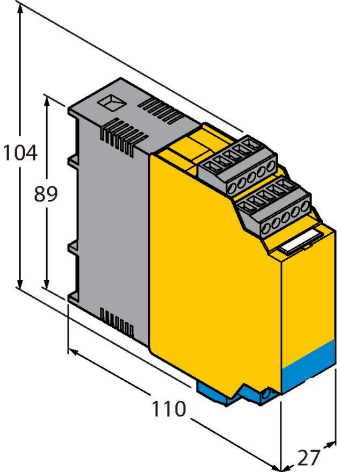
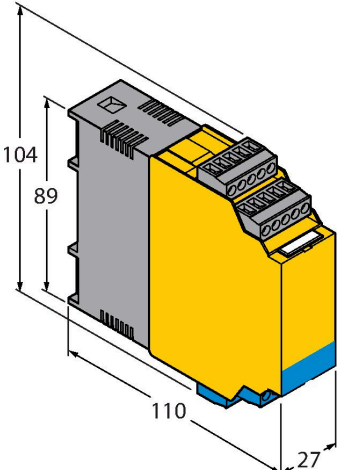
Dimension drawing	Type	ID	
	FMX-IM-3UP63X	7525101	Ex signal processor for Ex flow sensors from the FC....-NAEX... product series; operating voltage 20...30 VDC; LED bar for displaying flow speed and medium temperature; IO-Link device with transistor outputs for flow, temperature and errors
	FMX-IM-3UR38X	7525103	Ex signal processor for Ex flow sensors from the FC....-NAEX... product series; operating voltage 20...250 VAC; LED bar for displaying flow speed and medium temperature; IO-Link device with relay outputs for flow, temperature and errors

Dimension drawing	Type	ID	
	FMX-IM-2UPLI63X	7525105	Ex signal processor for Ex flow sensors from the FC...-NAEX... product series; operating voltage 20...30 VDC; LED bar for displaying flow speed and medium temperature; HART device with analog output for flow and transistor outputs for temperature and errors

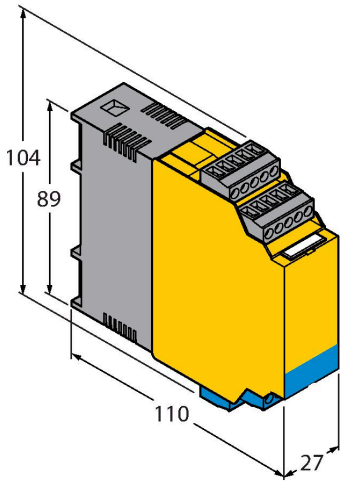

Instructions for use

Intended use

This device fulfills Directive 2014/34/EU and is suited for use in areas exposed to explosion hazards according to EN60079-0:2012 and EN60079-11:2012. In order to ensure correct operation to the intended purpose it is required to observe the national regulations and directives.

For use in explosion hazardous areas conform to classification

The sensors may be used only in dust or gas areas

II 2 G (Group II, Category 2 G, electrical equipment for gaseous atmospheres).

II 2 D (Group II, Category 2 D, electrical equipment for dust atmospheres).

Installation/Commissioning

These devices may only be installed, connected and operated by trained and qualified staff. Qualified staff must have knowledge of protection classes, directives and regulations concerning electrical equipment designed for use in explosion hazardous areas. Please verify that the classification and the marking on the device comply with the actual application conditions.

This device is only suited for connection to approved Exi circuits according to EN 60079-0 and EN 60079-11. Please observe the maximum admissible electrical values. After connection to other circuits the sensor may no longer be used in Exi installations. When interconnected to (associated) electrical equipment, it is required to perform the "Proof of intrinsic safety" (EN60079-14).

Installation and mounting instructions

Avoid static charging of cables and plastic devices. Please only clean the device with a damp cloth. Do not install the device in a dust flow and avoid build-up of dust deposits on the device. If the devices and the cable could be subject to mechanical damage, they must be protected accordingly. They must also be shielded against strong electro-magnetic fields. The pin configuration and the electrical specifications can be taken from the device marking or the technical data sheet. In order to avoid contamination of the device, please remove possible blanking plugs of the cable glands or connectors only shortly before inserting the cable or opening the cable socket.

Special conditions for safe operation

The device must be protected against any kind of mechanical damage.

Service/Maintenance

Repairs are not possible. The approval expires if the device is repaired or modified by a person other than the manufacturer. The most important data from the approval are listed.