

Accessories

Protective housing

SG40/2

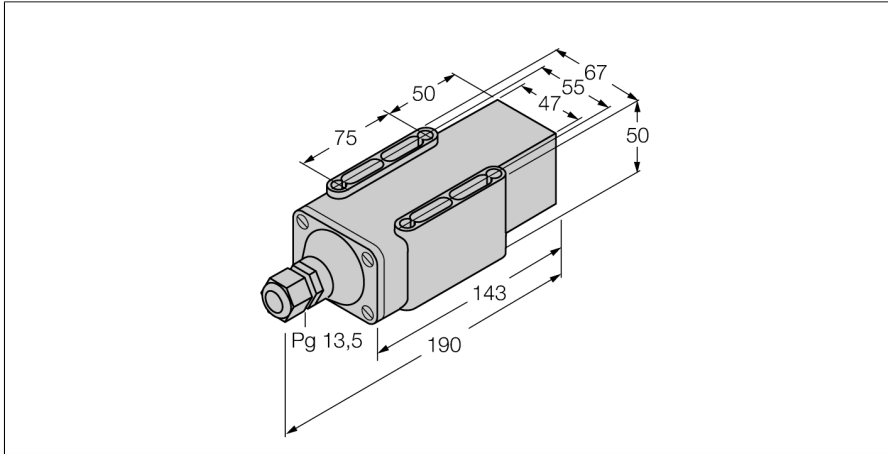

- Protective housing
- Plastic: ULTEM
- Temperature resistant up to +170 °C, especially UV and ozone resistant; Protection class IP68, 5 m wg

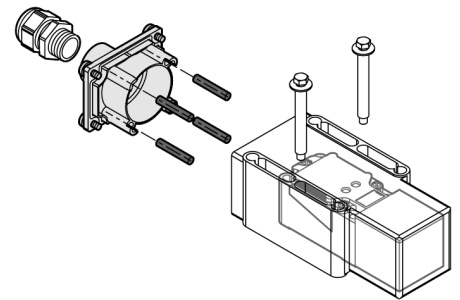

Type	SG40/2
ID	69497
Design	Accessories for rectangular sensor, CP40
Dimensions	143 x 67 x 50 mm
Housing material	Plastic, Ultem
Cable external diameter	5...12mm
Ambient temperature	-30...+170 °C
Protection class	IP68
Included in delivery	2 x spacer sleeves; 2 x clamp sleeves; 2 x M5 x 60 screws; 1x cable gland PG 13.5