

FW-ERSPM0516-SA-S-0408

Sahada montajı yapılabilir konektör

Erkek konektör, M12 × 1, düz

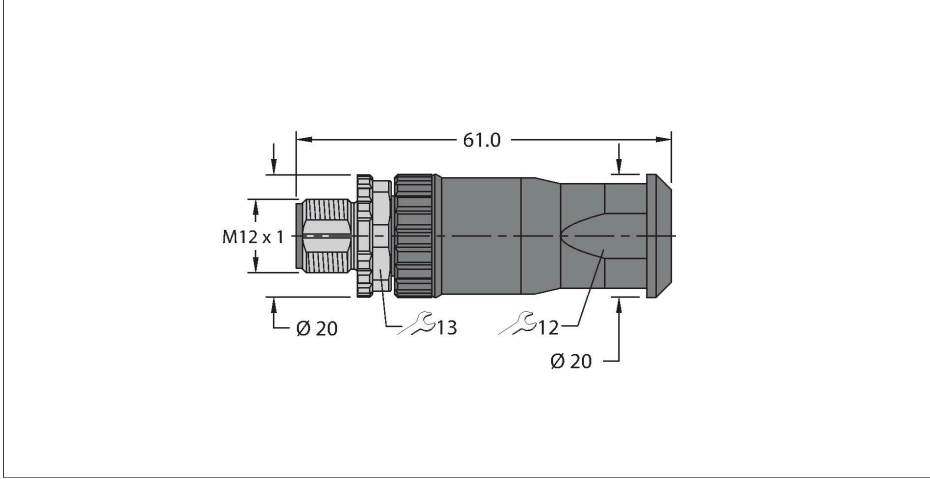

Özellikler



- Vidalı kenet terminali
- A kodlama
- 5 pimli
- Kablo beslemesi: 4,0...8,0 mm
- Terminal kapasitesi: 0,25...1,5 mm²
- Onay: cULus

Kontakt ataması

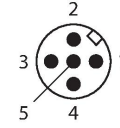

Teknik Veriler

Tip	FW-ERSPM0516-SA-S-0408
Tanıt. no.	100002289
Şunun yerine geçer:	100000589
Konektör A	Erkek konektör, M12 × 1, Düz, A kodlu
Pim sayısı	5
Kontaktlar	Pirinç, CuZn, Altın kaplama
Contact carriers	plastik, PA UL94-V0, Siyah
Connector body	plastik, PA6 GF, UL 94, Siyah
Kaplin somunu/vidası	Nikel kaplamalı pirinç, CuZn, nikel kaplama
Seal	plastik
Tightening torque (range)	0.4 ... 0.4 Nm (Karşı parçanın maks. tork değerine dikkat edin!)
Screw-in thread seal	FPM/FKM
External diameter of the cable	4...8 mm
Çekirdek kesiti/Kenetleme kabiliyeti	0.25...1.5 mm ²
Connection mode	Screw/clamp connection
Mekanik ömür	> 100 eşleşme döngüleri
Koruma tipi	IP67, (birbirine vidalanmış)
+20°C'de elektriksel özellikler	
Nominal gerilim	60 V
Akım	4 A
Insulation resistance	≥ 10 ⁸ Ω
Mekanik ve kimyasal özellikler	
Ortam sıcaklığı (sabit)	-40...+85 °C

Teknik Veriler

Onaylar

cULus
