

BL67 electronic module

RS485/422 Interface

BL67-1RS485/422

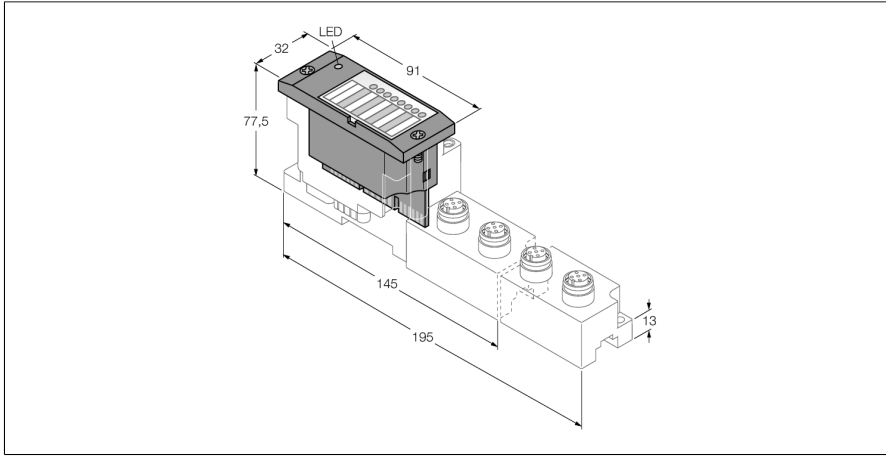

- Kullanılan fieldbus ve bağlantı teknolojisinden bağımsız
- Koruma sınıfı IP67
- LEDs indicate status and diagnostic
- Electronics galvanically separated from the field level via optocouplers
- Transmission of serial data via RS485/422 interface
- For connection of printers, light screens and bar code scanners e.g.

İşlevsel prensip



BL67 electronic modules are plugged on the purely passive base modules which in turn are connected to the field devices. The separation of connection level and electronics simplifies maintenance considerably. Flexibility is enhanced because the user can choose between base modules with different connection technologies.

The electronic modules are completely independent of the higher level fieldbus through the use of gateways.

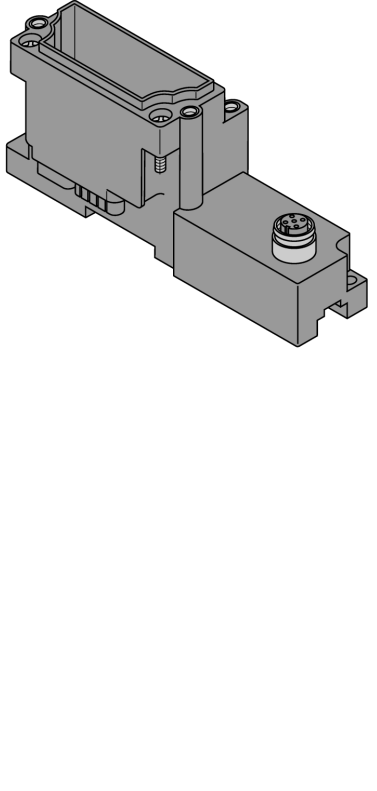
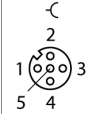
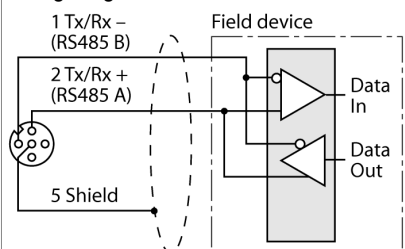
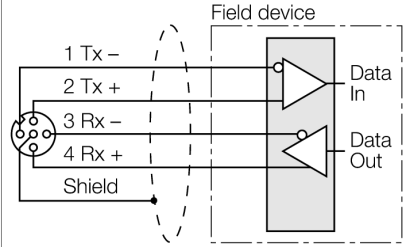
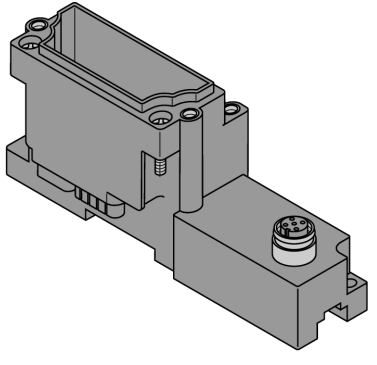
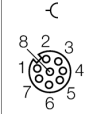
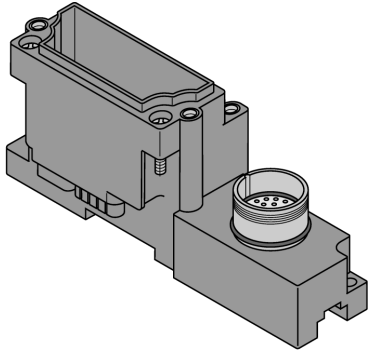

Tip	BL67-1RS485/422
Tanit. no.	6827192
Kanal sayısı	1
Besleme gerilimi	24 VDC
Nominal voltage V _n	24 VDC
Alan beslemesinden gelen nominal akım	≤ 50 mA
Modül veri yolundan gelen nominal akım	≤ 60 mA
Güç dağılımı, tipik	≤ 1 W
Girişler/çıkışlar	
İletim sinyalleri	TxD, RxD
Bağlantı türü	2 kablolu yarı dubleks ya da 4 kablolu tam dubleks
Transmission rate	300 ile 115.200 b/sn arası
Parametreler	RS485/422, transmission rate, diagnostics, data bits, stop bits, XON - character, XOFF - character, parity, flow control
Kablo uzunluğu	30 m
Hat empedansı	120 Ω
Sonlandırma direnci	external
Elektrik yalıtımı	isolation of electronics and field level via optocouplers
Çıkış bağlantısı	
	M12, M23
Giriş bayt sayısı	8
Çıkış bayt sayısı	8

Boyutlar (W x L x H)	32 x 91 x 59 mm
Onaylar	CE, cULus
Ortam sıcaklığı	-40...+70 °C
Saklama sıcaklığı	-40...+85 °C
Bağıl nem	%5...95 (dahili), seviye RH-2, yoğuşmasız (45°C'de depolandığında)
Titreşim testi	EN 61131 uyarınca
- up to 5 g (at 10 to 150 Hz)	for mounting on DIN rail no drilling according to EN 60715, with end bracket
- up to 20 g (at 10 up to 150 Hz)	for mounting on base plate or machinery Therefore every second module has to be mounted with two screws each.
Darbe testi	IEC 60068-2-27 uyarınca
Düşme ve devrilme	acc. to IEC 68-2-31 and free fall to IEC 68-2-32
Elektromanyetik uyumluluk	EN 61131-2 uyarınca
IP Derecesi	IP67
Tightening torque fixing screw	0.9...1.2 Nm

Compatible base modules

Ölçekli çizim	Type	Pin configuration
	<p>BL67-B-1M12 6827185 1 x M12, 5-pole, female</p> <p>Comments Zırhlı bağlantı kablosu (örnek): RKC5.501T-2-RSC5.501T/TXL Tanım. No. 6628831</p>	<p>Tel ataması</p>  <p>1 = Tx - (RS485 B) 2 = Tx + (RS485 A) 3 = Rx - 4 = Rx + 5 = shield</p> <p>Wiring Diagram for RS485</p>  <p>Wiring diagram for RS422</p> 
	<p>BL67-B-1M12-8 6827193 1 x M12, 8-pole, female</p> <p>Comments Pin configuration see above. matching connection cable (for example) BS8181-0 Ident no. 6901004</p>	<p>Tel ataması</p>  <p>1 = Rx + 5 = Rx - 2 = Tx + (RS485 A) 6 = GND_{ISO} 3 = Tx - (RS485 B) 7 = n.c. 4 = n.c. 8 = shield</p>
	<p>BL67-B-1M23 6827213 1 x M23, 12-pole, female</p> <p>Comments Pin configuration see above. matching connection cable (for example): FW-M23ST12Q-G-LT-ME-XX-10 Ident no. 6604070</p>	<p>Tel ataması</p>  <p>1 = Rx + 7 = n.c. 2 = Tx + (RS485 A) 8 = shield 3 = Tx - (RS485 B) 9 = n.c. 4 = n.c. 10 = n.c. 5 = Rx - 11 = Tx - 6 = GND (iso) 12 = n.c.</p>

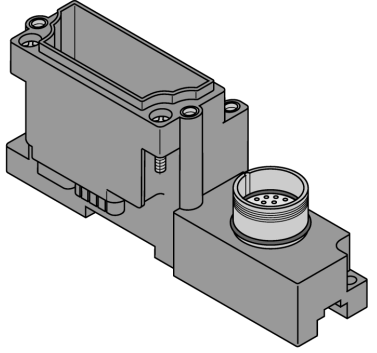
Compatible base modules

Ölçekli çizim	Type	Pin configuration												
	<p>BL67-B-1M23-VI 6827290 1 x M23, 12-pole, female</p> <p>Comments Pin configuration comparable with BL67-B-1M12 (see above). Additionally with 24 VDC sensor supply.</p>	<p>Tel ataması</p>  <table border="0"> <tr> <td>1 = Rx +</td> <td>7 = n.c.</td> </tr> <tr> <td>2 = Tx + (RS485 A)</td> <td>8 = shield</td> </tr> <tr> <td>3 = Tx - (RS485 B)</td> <td>9 = V_{SENS}</td> </tr> <tr> <td>4 = n.c.</td> <td>10 = V_{SENS}</td> </tr> <tr> <td>5 = Rx -</td> <td>11 = V_{SENS}</td> </tr> <tr> <td>6 = GND (iso)</td> <td>12 = GND</td> </tr> </table>	1 = Rx +	7 = n.c.	2 = Tx + (RS485 A)	8 = shield	3 = Tx - (RS485 B)	9 = V _{SENS}	4 = n.c.	10 = V _{SENS}	5 = Rx -	11 = V _{SENS}	6 = GND (iso)	12 = GND
1 = Rx +	7 = n.c.													
2 = Tx + (RS485 A)	8 = shield													
3 = Tx - (RS485 B)	9 = V _{SENS}													
4 = n.c.	10 = V _{SENS}													
5 = Rx -	11 = V _{SENS}													
6 = GND (iso)	12 = GND													

LED display

LED	Color	Status	Meaning
D		OFF	No error message or diagnostics active.
	RED	ON	Failure of module bus communication. Check if more than 2 adjacent electronic modules are pulled. Relevant modules are located between gateway and this module.
	RED	FLASHING (0.5 Hz)	Upcoming module diagnostics
TxD		OFF	Data is currently not transferred.
	GREEN	ON	Data is currently transferred
RxD		OFF	Data is currently not received.
	GREEN	ON	Data is currently received

Data mapping

DATA	BYTE	Bit 7	Bit 6	Bit 5	Bit 4	Bit 3	Bit 2	Bit 1	Bit 0	
Input	n	STAT	TX_CNT_ACK		RX_CNT		RX_BYTE_CNT			
	n+1	Buf Ovfl	Frame Err	HndSh Err	HW Failure	Prm Err	reserved			
	n+2	Data byte 0								
	n+3	Data byte 1								
	n+4	Data byte 2								
	n+4	Data byte 3								
	n+6	Data byte 4								
	n+7	Data byte 5								
Output	m	STATRES	RX_CNT_ACK		TCX_CNT		TX_BYTE_CNT			
	m+1	reserved						RXBUF FLUSH	TXBUF FLUSH	
	m+2	Data byte 0								
	m+3	Data byte 1								
	m+4	Data byte 2								
	m+4	Data byte 3								
	m+6	Data byte 4								
	m+7	Data byte 5								

n = Offset of input data; depending on extension of station and the corresponding fieldbus.

m = Offset of output data; depending on extension of station and the corresponding fieldbus.

With PROFIBUS, PROFINET and CANopen, the I/O data of this module is localized within the process data of the whole station via the hardware configuration tool of the fieldbus master.

With DeviceNet™, EtherNet/IP™ and Modbus TCP a detailed mapping table can be created with the TURCK configuration tool I/O-ASSISTANT.

Note:

A software function module is available for simple handling of the serial interfaces (RS232, RS485 and RS422). Such a function module is available for the CoDeSys programmable BL67 gateway and for the S7 PLC systems.

The actual sequence of the data of the RSxxx modules in the process data of the higher-level control system may vary from that shown here. The sequence in Profibus systems is generally the reverse (byte 0 complies with byte 7 etc.).